

MARCH, 1933

Radio Engineering

IN THIS ISSUE



AN INTER-CARRIER NOISE SUPPRESSION
SYSTEM

By Norman E. Wunderlich

ANTENNA TRANSMISSION LINE SYSTEMS FOR
RADIO RECEPTION

By C. E. Brigham

RECENT DEVELOPMENTS IN CATHODE RAY
TUBES AND ASSOCIATED APPARATUS

By Allen B. DuMont

RADIO RECEIVER DESIGN

By J. E. Smith

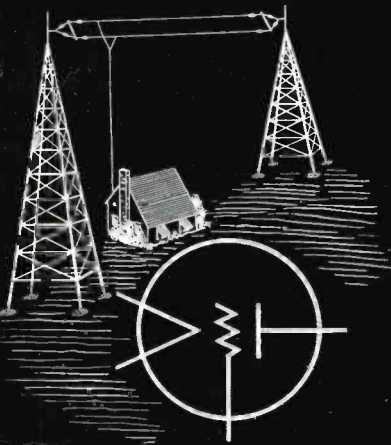

THIRTEENTH YEAR OF SERVICE

The Journal of the
Radio and Allied Industries

SET MANUFACTURERS ARE

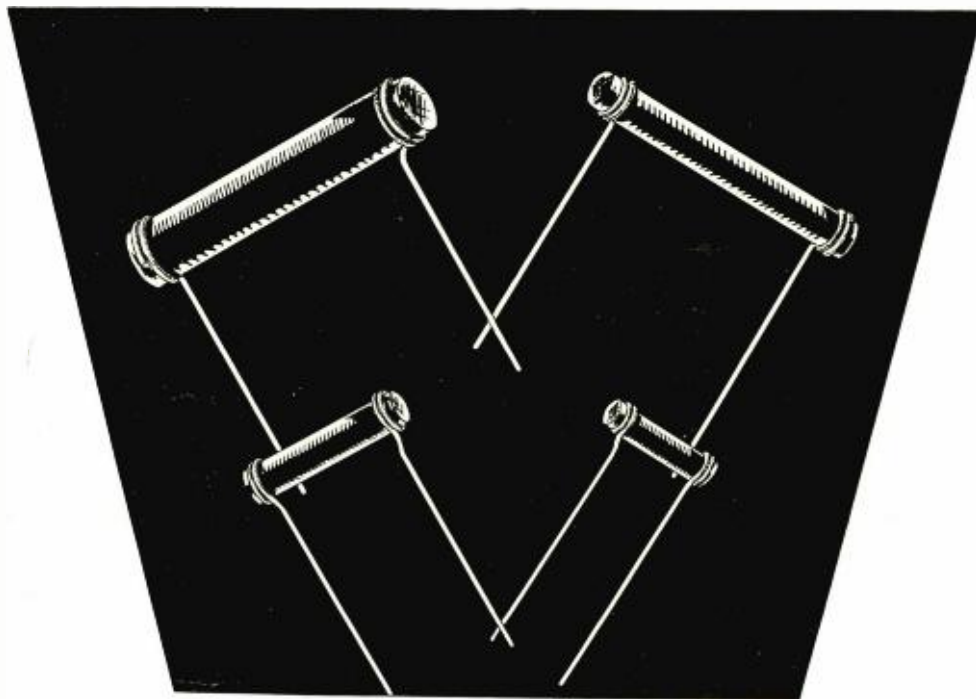

SAVING WITH

Manufacturers of radio sets are effecting appreciable savings with Erie Resistors because only one stock need be carried where the same resistance value is to be used on different voltages.

This is possible because the change of resistance with voltage is very small in Erie Resistors. In fact it is less than 2% in the majority of cases.

It is not necessary to specify the testing voltage except where special precision is necessary.

The manufacturing processes by which Erie Resistors are made has been developed over a period of years—every step in the development of Erie Resistors has resulted in new and improved methods.

When you specify Erie Resistors you are getting the very best moulded type resistors of fixed resistance value that the market affords.

Ask for book of data sheets showing test charts which fully explain the technical data on Erie Resistor Corporation High Resistance Products.

ERIE SUPPRESSORS

An Erie Suppressor Resistor will not fail mechanically at 120°C and 100% relative humidity.

The resistance unit is enclosed in a ceramic tube to protect it from mechanical breakage as well as from oil, dirt and moisture.

ERIE RESISTORS



ERIE RESISTOR CORPORATION, ERIE, PA.
Factories in Erie, Pa., Toronto Can., and London, Eng.



**IN
STATIONS OF
100 WATTS TO
1000 WATTS**



Western Electric 12A Transmitter (right) and 9A Speech Input Equipment (left) as installed at Station WHAT, Philadelphia



Control room at WHAT, showing 9A Speech Input Equipment with Moving Coil Microphone and Western Electric Reproducer Set

**. . . . Western Electric 12A Transmitters
assure quality, compactness, efficiency, economy!**

Rated at 100 watts, the Western Electric 12A Radio Broadcasting Transmitter is noted for unusual frequency stability and fidelity of transmission. Complete absence of rotating machinery—100% grid bias modulation—all tubes radiation cooled, are some of its outstanding features.

For power higher than 100 watts, the 12A Transmitter is used as the driver for the 71A Amplifier. This combination will deliver 250, 500 or 1000 watts, depending primarily upon what tubes are used in the output stage.

Floor space of only 25" x 36" is required for complete

100 watt transmitting equipment. The amplifier—giving increased power up to 1000 watts—requires additional floor space of like area. The Western Electric Moving Coil Microphone and an efficient all AC operated single rack Speech Input Equipment have been designed for use with these transmitting equipments.

Many innovations in design result in unusually high quality performance and economical operation. That's why leading stations have increased their popularity—and their revenues—with the Western Electric 12A and 71A. Send the coupon to Graybar for complete information.

Western Electric

RADIO TELEPHONE BROADCASTING EQUIPMENT

Distributed by GRAYBAR Electric Company

GRAYBAR ELECTRIC CO.	RE 3-33
Graybar Building, New York, N. Y.	
Gentlemen: Please send me full information on the Western Electric 12A Radio Transmitter and 71A Amplifier.	
NAME	
ADDRESS	
CITY STATE	

RADIO ENGINEERING

Reg. U. S. Patent Office



Western Editor
ULMER G. TURNER

Editor
DONALD McNICOL

Managing Editor
F. WALEN

Vol. XIII

MARCH, 1933

Number 3

Contents

	PAGE
EDITORIAL	4
A CHRONOLOGICAL HISTORY OF ELECTRICAL COMMUNICATION—TELEGRAPH, TELEPHONE AND RADIO, PART XV...	5
AN INTER-CARRIER NOISE SUPPRESSION SYSTEM <i>By Norman E. Wunderlich</i>	7
THE CONCENTRATOR ANTENNA.....	10
NOISE INTENSITY IN RADIO RECEPTION <i>By Professor J. F. Byrne</i>	10
ANTENNA TRANSMISSION LINE SYSTEMS FOR RADIO RECEPTION..... <i>By C. E. Brigham</i>	11
A TELEVISION PROJECTOR.....	13
RECENT DEVELOPMENTS IN CATHODE RAY TUBES AND ASSOCIATED APPARATUS..... <i>By Allen B. DuMont</i>	15
RADIO RECEIVER DESIGN..... <i>By J. E. Smith</i>	20

Departments

NEWS OF THE INDUSTRY.....	24
NEW DEVELOPMENTS OF THE MONTH.....	26
INDEX OF ADVERTISERS	30

TUBE MANUFACTURERS

THE trend continues for the consolidation of tube manufacturing units. R. C. A. Radiotron acquires the DeForest Company. Sylvania has been strengthened by acquiring control of another of the smaller companies which has made a good product.

Arcturus produces numerous excellent tube products and the company enjoys high standing in the radio industry.

Four years ago there were about twenty-five companies in the United States manufacturing tubes. Wear and tear have reduced the number to less than a dozen.

In constructive trade circles it is agreed that the radio industry could support four or five major tube manufacturing groups, the elements of competition to be service, quality, credit and engineering cooperation with set manufacturers.

BRYAN S. DAVIS
President

JAS. A. WALKER
Secretary

Published Monthly by

Bryan Davis Publishing Co., Inc.
19 East 47th Street
New York City

SANFORD R. COWAN
Advertising Manager

J. E. NIELSEN
Circulation Manager

Chicago Office—1221 Rosemont Ave.—Charles H. Farrell, Mgr.
St. Louis Office—305 Star Building—F. J. Wright
Kansas City, Mo. Office—306 Coca Cola Building—R. W. Mitchell
Cleveland Office—Millard H. Newton, 316 National Bldg.

Philadelphia Office—1315 N. 13th St.—H. S. Thoenebe.

San Francisco Office—135 Sansome St.—R. J. Birch
Los Angeles Office—846 S. Broadway—R. J. Birch
New Zealand—Tearo Book Depot—Wellington.
Melbourne, Australia—McGill's Agency.

Entered as second class matter August 26, 1931, at the Post Office at New York, N. Y., under Act of March 3, 1879. Yearly subscription rate \$2.00 in United States. \$3.00 in Canada and foreign countries.

Hex Head—preferred by so many—now a standard Self-tapping Screw



It may increase your assembly speed—and now it costs no more

PHILCO started it. They were saving a lot of time and labor through the use of the slotted head Parker-Kalon Hardened Self-tapping Sheet Metal Screws but they told us they could speed up their assemblies even more if they did not have to drive in the Screws with a screw driver. So we made the Screws with a hexagon head for them. The idea proved a success. And, before long other radio manufacturers discovered that they, too, could use a Hex Head Self-tapping Screw to advantage. But because it was specially made, the price on the Hex Head Screw was necessarily higher and besides, a fairly large quantity had to be ordered.

Now, the wide acceptance of the Hex Head Screw has justified our making it a standard item in a large range of sizes. And the prices on them are the same as for corresponding sizes of the slotted head Self-tapping Screws.

You may find that the Hex Head Self-tapping Cap Screw will speed up your assembly work . . . eliminate difficulty and loss of time caused by screw driver blades slipping out of the slots . . . prevent damage to screw heads. We suggest that you try it and see what it offers in greater fastening ease and speed.

Get samples - free - for a trial

Try the Hardened Self-tapping Cap Screws and see what they will save you. Just send a brief description of your assemblies and we will furnish suitable samples for test . . . free.

PARKER-KALON CORPORATION
Dpt. L, 190-198 VARICK ST., NEW YORK, N. Y.

PARKER-KALON
HARDENED  SELF-TAPPING
CAP SCREWS
PATENTED IN U.S.A. 1928, 1929, 1930, 1931

Typical Assemblies

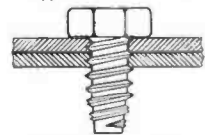

Light Sheet Metal

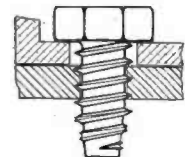

Fastening to heavy plate or structural shape

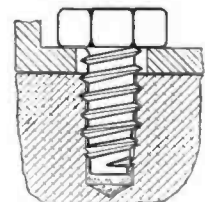

Fastening to aluminum casting or the like

E d i t o r i a l

MARCH, 1933

TUBE SALES POLICY

THERE is speculation as to whether the tube sales policy being tried out in England would be workable in America. The plan provides that there shall be a price for tubes used as initial equipment in manufactured receivers, and a price (higher) for tubes sold to dealers for replacement purposes.

Obviously the plan contains the seeds of temptation to violate the distinction between "original" and "replacement" tubes, in order to profit thereby. Also, it may be contended that actually this system is in use here by virtue of the quotations made to set manufacturers for tubes in quantity.

It is remarkable how an industry, like an individual, is driven either from within or without. If it were not that the same thing is in these times true in respect to other products, one might well wonder why all the effort to reduce prices to a no profit basis—all effort being devoted to the interest of the ultimate consumer, who is little interested and to whom the difference of a few cents in the cost of a radio tube signifies practically nothing.

RADIO FOR EXPORT

THE half starved horse, limping along one side of a stout, high fence beyond which ripened a field of thick topped timothy hay, was in a predicament similar to that of the world's manufacturers who produce more than their nationals can possibly purchase at prices leaving reasonable profit for the manufacturer.

Even though there exist serious difficulties of currency differences, high tariffs, and embargoes on money outgo beyond national borders, the demand grows for radio receivers in Spain, Portugal, Poland, India, and in other European and Asiatic countries, and in South America. This demand is so persistent that it is astonishing the number of receivers that are being sold at from \$150.00 to \$350.00, each.

Exporters say they have numerous calls

from abroad for descriptions and prices of receiver accessories. Agents in America for foreign commercial organizations are now active in devising ways and means of supplying the needs of merchandise distributors in other countries.

Hardly a day passes that a representative of foreign radio interests does not visit the offices of RADIO ENGINEERING in search of light on this subject. No doubt other products of manufacture are equally affected. No doubt, also, the situation is an element of the foreign debt impasse.

In many quarters high hopes are entertained that soon the barriers shall be removed permitting the currents of trade to flow as of yore.

VERTICAL GROUNDS FOR SIGNAL STRENGTH

THE experiment at WOKO, Albany, N. Y., in which a two nought copper cable was laid from the surface to the bottom of a 114 feet deep artesian well, is reported to have added a gain of 12.7 millivolts per meter, an increase of about 20 per cent in signal strength.

The vertical earth contact was tied into the ground system previously in use, the gain being noted after the tie-in.

In drilling the well, water was encountered at various levels, and when completed the water level was within six feet of the surface of the earth.

For transmitting stations located where it is not convenient to employ extensive ploughed underground networks, the vertical ground tied into a surface network over a relatively limited area may have worthwhile possibilities.

Donald Mc Nicol
Editor.

A chronological history of electrical communication

—telegraph, telephone and radio

▲

This history was begun in the January, 1932, issue of RADIO ENGINEERING, and will be continued in successive monthly issues. The history is authoritative and will record all important dates, discoveries, inventions, necrology and statistics, with numerous contemporary chronological tie-in references to events in associated scientific developments. The entries will be carried along to our times.

▼

Part XV

1881 (Continued)

- (569) The Montreal Telegraph Company, in Canada, has 12,704 miles of pole line, 21,568 miles of wire, and 1,674 offices. The gross annual revenue is \$550,840.01, and the expenses \$358,676. Hugh Allan is president of the company.
- (570) The New York Electrical Society is organized, February 23, by a group of telegraph officials, including P. J. Tierney, D. R. Downer, J. W. Moreland, E. T. Barberie, E. A. Leslie, F. W. Cushing, A. T. Creelman, J. H. Dwight, J. B. Sabine, W. B. Waycott, F. Stainton, F. W. Jones, George B. Scott, Gerrit Smith, W. J. Dealy, George A. Hamilton, George G. Ward and M. Brick. F. W. Jones is elected first president.
- (571) The consolidation takes place of the Western Union Telegraph Company, American Union Telegraph Company and Atlantic and Pacific Telegraph Company, January 19.
- (572) The Mexican Telegraph Company's cable between Brownsville, Tex., and Vera Cruz, Mexico, is opened for public service, March 11.
- (573) The Bankers and Merchants Telegraph Company organized, March 22, with a capital of \$1,000,000.
- (574) At Cleveland, Ohio, a Brush electric lamp using carbons two inches in diameter, is estimated to yield 100,000 candle power.
- (575) Charles Adams Randall, of New York, procures a patent (No. 238,713) for a chemical telegraph system.
- (576) An arc lighting system is placed in service in Denver, Colo.
- (577) William A. Leggo, of New York, procures a patent (No. 238,929) for an automatic telegraph system.
- (578) A large number of American patents are issued to T. A. Edison, for inventions in incandescent lamp electric lighting.
- (579) Shelford Bidwell, in London, reads a paper on the subject: "Telegraphic Transmission of Pictures of Natural Objects."
- (580) Amos E. Dolbear, of Somerville, Mass., procures a patent (No. 239,742) for apparatus for transmitting sound by electricity.
- (581) P. B. Delany, of New York, procures a patent (No. 240,236) for a method of insulating and protecting electric conductors.
- (582) G. A. Cardwell and Nelson L. North, of Brooklyn, N. Y., procure a patent (No. 240,383) for a telephone alarm bell.
- (583) Henry Van Hoevenberg, of Elizabeth, N. J., procures a patent (No. 241,094) for a printing telegraph system.
- (584) The Postal Telegraph-Cable Company is organized. June 21. (The company was reorganized on October 19, 1883.)
- (585) Joseph Wilson Swan, in England, invents an incandescent electric lamp. The Swan Electric Light Company is organized at Newcastle. This was the first electric lamp manufactory in Europe.
- (586) Nikola Tesla, employed in the Hungarian telegraph service, at Budapest, takes up the study of the electric light. (In 1884 Mr. Tesla emigrated to the United States.)
- (587) At Antwerp, Belgium, C. Faraday Proctor constructs incandescent electric lamps—probably the earliest commercial electric lamps of this type made on the continent.
- (588) Insurance underwriters and electrical interests in the United States draft rules and regulations governing the installation of electric wires in buildings.
- (589) Henry Hunnings, of England, secures an American patent (No. 246,512) covering a granulated carbon telephone transmitter. (Patent granted in England September 16, 1878.)
- (590) Major Cardew, of the British army, employs the telephone and Morse buzzer systems of communication in army signaling.
- (591) The Montreal Telegraph Company is absorbed by the Great North Western Telegraph Company.
- (592) The American Telegraph and Cable Company is formed by Jay Gould. One transatlantic cable is laid during the year and is leased by the Western Union Telegraph Company. (A second cable was laid in 1882.)
- (593) Leroy B. Firman's patent (No. 252,576) granted, January 17, covering the invention of the principle of the multiple switchboard for telephone circuits.
- (594) Joubert suggests the Stroboscopic method of observing optical phenomena in alternating-current arc circuits.
- (595) The cable rate from New York to Great Britain, Ireland and France is reduced to twenty-five cents per word, August 1.
- (596) An International Electrical Exhibition is opened at Paris, France, August 10. A dozen or more American manufacturers are represented by exhibits of apparatus. The Electrical Congress adopts the *ampere* as the unit of strength of the electric current; the *coulomb* as the practical unit of electrical quantity; the *volt* as the unit of electromotive force; the *ohm* as the unit of electric resistance, and the *farad* as the unit of electrostatic capacity.
- (597) The United States patent office has so far granted about 175 patents covering inventions for electric lighting, and about 300 additional patent applications are pending.
- (598) The capital stock of the Western Union Telegraph Company has been increased to \$80,000,000.
- (599) Erastus Wiman is elected president of the Great North Western Telegraph Company, Canada.
- (600) The Board of Fire Underwriters of New York City adopt regulations governing the installation of electric wires in buildings.
- 1882 (601) Railroad trains are dispatched on the N.Y.W.S. and B. R. R. between Athens and St. Johnsville, N. Y., by means of the telephone.
- (602) John E. Wright and J. H. Longstreet, New York, introduce an improved stock ticker instrument.
- (603) An Edison electric light station is opened in London, England, January 12. 3,000 lamps are connected.

(To be continued)

CORRECTION

On page 23, January, 1933, issue of RADIO ENGINEERING, "Chronological History of Communication," the second item, No. 517, should be No. 518, reading: "An International Telegraph Convention is held, in London."

SHAKEPROOF



"If every manufacturer had a Proving Ground"

WHEN Lock Washers are bought on performance, Shakeproof is immediately recognized as the leader of them all. No other lock washer can hold a connection so tight and provide such perfect protection against vibration. This has been proved by the automobile industry time and time again and that's why Shakeproof Lock Washers enjoy the confidence of America's leading automotive

engineers. They know that the multiple locking principle, plus the tremendous holding power of the twisted steel teeth, assures improved performance and lasting satisfaction for their customers. If you would like to make your product better—get acquainted with Shakeproof's many production advantages. Send for testing samples and our complete new catalog—mail the coupon below, today!



Shakeproof representatives are located in the following cities:

- New York
- Philadelphia
- Boston
- Pittsburgh
- Schenectady
- Detroit
- Cleveland
- Milwaukee
- Toledo
- Cincinnati
- Dallas, Tex.
- Birmingham, Ala.
- Los Angeles
- San Francisco
- Seattle
- Toronto, Ont., Can.



SHAKEPROOF Lock Washer Company

(Division of Illinois Tool Works)

2509 N. Keeler Avenue

Chicago, Illinois

Coupon Gentlemen: Kindly send us your complete catalog and price list. Also, please send us testing samples as indicated.

Type..... Size.....

Type..... Size.....

Firm Name.....

Address.....

City..... State.....

By..... Title.....

Type 12. Internal. For S. A. E. and Standard Machine Screws

Type 11. External. For Standard Bolts and Nuts

Type 15. Countersunk. For all Countersunk Screws

Type 20. Locking Terminals. For Radio and Electrical Work

U. S. Patents
1,419,564—1,604,122
1,697,954—1,782,387
Other Patents Pending. Foreign Patents.

RADIO ENGINEERING

FOR MARCH, 1933



A simplified and improved method for silent tuning. An exceptional 7-tube superhet with amplified avc and noise suppression.

An inter-carrier noise suppression system

By NORMAN E. WUNDERLICH

THIS method of inter-carrier noise suppression has all of the practical advantages of most of the more complicated systems without their disadvantages and does not require the use of any additional tubes to secure such results. It may be applied to either the superheterodyne circuit or the t.r.f. receiver when either has six or more tubes. As the superheterodyne is of more general interest, the description herein deals with the application of this new system and the B tube to a typical type of 7-tube receiver and one which is now being prepared for commercial production.

Inter-carrier noise suppression, sensitivity control and amplified automatic gain control are all obtained in this system without the use of additional tubes and by a method which is without circuit or operational difficulties. It is considerably less expensive than any of the other methods and possesses features which make it highly desirable for a commercial product. These results are attained by taking advantage of

circuit arrangements made possible by the electrode construction of the B tube.

The B Tube

Fig. 1 shows the construction of the new B tube and the arrangement of the elements. The tube has recently been placed in production. The element structure of this new tube is quite similar to the standard A tube with the exception that the cathode has been made longer and a small, extra anode which is shielded from the other elements, is placed at the top of the structure.

The extra anode is brought out to a top connector and the shield is grounded through the cathode sleeve. All of the other elements are exactly the same as in the previously announced Wunderlich tube and connect to the 6-pin base in the same way.

This extra anode and extra diode formed by the cathode-anode make possible a great variety of valuable circuit arrangements.

In the circuit and application under

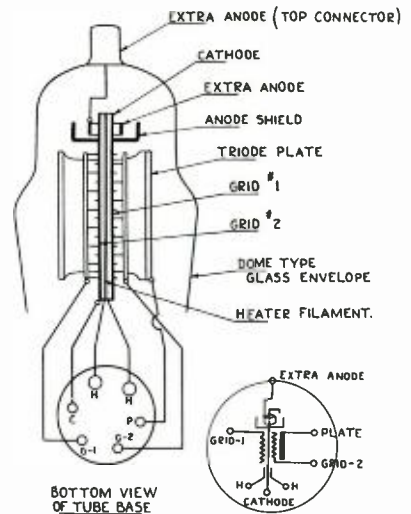

Fig. 1.

consideration, the extra anode acts as a one way valve to permit only the *negative* charges to flow out along the avc buss line. Thus, regardless of any unbalance of potentials, positive potentials, in respect to ground, cannot flow to the grids and only the desired, negative potentials will be released along this lead to the grids of the tubes under control.

Circuit Performance

Performance curves taken on one of the original models are shown in Fig. 2. These four curves of input versus output were taken at four different settings of the sensitivity or noise suppression level control and show how the "threshold" level of the receiver may be set to any desired value while retaining the automatic volume control action. These results are obtained by arranging the circuits and balancing the potentials so that the sustaining action of the automatic volume control may be caused to release at any desired, lower signal level.

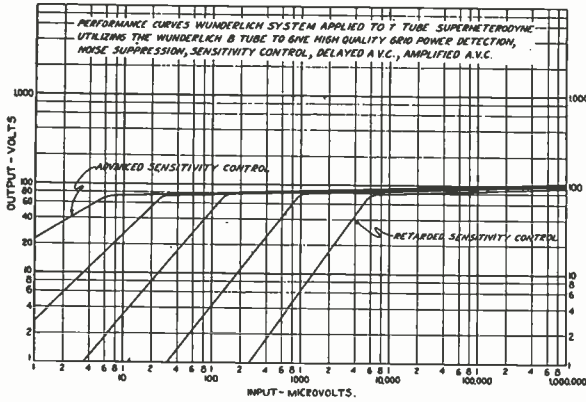

Fig. 2.

The point of release may be adjusted by means of the sensitivity control. This action is very sharply defined because of the fact that the potentials applied to the automatic control system are amplified to just the correct degree. This amplification of the avc action is made possible by the use of the new tube and in addition to this advantageous, sharply defined releasing action for noise suppression, it also makes it possible to adequately handle high signal input levels without overloading of the second detector nor any of the preceding tubes and thus tends to further improve the quality. All of the tubes ahead of the second detector may be placed under full governing action of the automatic gain control, which increases greatly the latitude of avc and the effectiveness of the whole system.

The adjustments required in the operation of the receiver are simple and easily understood. The sensitivity threshold level may be set to meet prevailing noise conditions by means of either a variable resistor or a tapped switch with various resistor steps. The operation of tuning and control of the level of audio volume are carried out in the conventional manner. The only new feature which the customer must acquaint himself with is the simple setting of the knob which determines the threshold level.

Details of the Circuit Arrangement

It will be seen from the circuit in Fig. 3 that the principal departure from conventional 7-tube superheterodyne arrangement lies in the connection of the second detector, the new B tube and the sensitivity control. In previously published circuits for the Wunderlich tube, the potentials for the avc have been obtained from the rectified carrier by making a connection to the grid leak. In the present circuit under consideration, the automatic control potentials are derived from the power supply system by making a connection to the extra anode of the B tube, second detector. Potentials so obtained

have the benefit of the amplifying function of the tube, thus affording higher avc potentials and decidedly more sharply defined avc action than can be secured from those systems which derive their avc voltage directly from the rectification of the carrier.

In carrying out the amplified avc control, the cathode of the detector should be connected through resistors to a point in the power supply which is approximately 100 volts negative with respect to ground. This may be conveniently obtained by placing the speaker field winding in the negative return of the power system, as shown in the circuit diagram. If the drop of potential across the speaker winding is more, or less, than 100 volts, the value of the resistors should be changed correspondingly so that the drop across them due to the plate current will just equal the drop across the field winding, when no signal is being received.

The plate of the detector should preferably be connected through the primary of a 1:2 step-up, center-tapped audio choke having a d-c. resistance of about 5800 ohms total winding, to a point in the power supply which is approximately 100 volts positive with respect to ground. The screen-grid buss of the amplifier tubes is usually most convenient for this B supply point.

The use of an iron core step-up auto-transformer in the plate of the tube

serves two purposes; (1) it increases the audio-frequency potentials applied to the output tube, and (2) it increases the potential variations across resistors, thereby sharpening the action of the avc system and increasing the avc potentials.

The operation of the circuit functions in the following manner: When no signal is being received, the potential drop in the tube plus the potential drop in the primary of the auto-transformer approximately offset the drop of potential across resistors in the cathode of the Wunderlich tube. As the drop in the cathode resistors is approximately equal to, and in the opposite polarity to the drop across the speaker field winding to which it is connected, the resulting condition will be one of having no difference of potential between the cathode of the tube and the chassis ground. In other words, the cathode of the second detector will be "floating" at about ground potential. And likewise the extra anode will be at the same potential except that it will act as a one way valve to permit passage of only the desired, *negative* potentials for the avc bias on the grids under control. In practice it is usually convenient to make or adjust either resistors, or the positive and negative potentials, so that the cathode is a few volts positive with respect to ground when no signal is being received. Because the extra anode-cathode will only pass negative potentials, this positive voltage does not reach the grids of the r-f. and i-f. tubes and it requires some definite signal carrier to overcome this few volts before the cathode point becomes negative, at which time avc bias voltage will begin to flow. This provides a delayed, or "fixed-level" avc action, which is desirable.

When a signal is tuned in, the grid of the detector acts as a full-wave grid rectifier and becomes negatively charged with respect to the detector cathode. This increases the resistance of the detector tube and lowers the plate current through it and likewise, through the resistors. The reduced potential

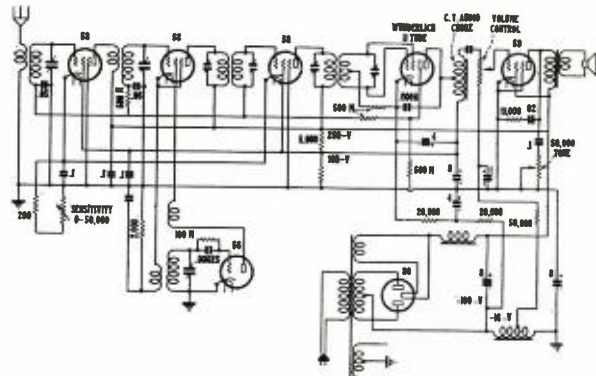

Fig. 3. Modified superheterodyne system.

The Concentrator Antenna

BY doubling the signal intensity of KYW, with no increase in station power, engineers of the Westinghouse Electric and Manufacturing Company have performed what is said to be the first major radio achievement of 1933 and have added a new term to radio—the concentrator antenna.

According to Walter C. Evans, manager of the Westinghouse radio department, some of the attributes of the new antenna system thus far noted are:

Increases signal intensity, approximately double, in areas where desired.

Moves fading area to a considerable distance from the station, and so increases the effectiveness of the station in its useful area.

Is most efficient on higher frequencies, and improves the lower wavebands for broadcasting operations. (This last may be its most important function.)

The new system at KYW, developed after months of research and experimentation, consists of two unusually high vertical antennas, with a new ground system. Vertical copper rods have taken the place of the more familiar antenna where wires are strung between towers.

The main antenna—engineers term it the exciter—consists of a copper rod, 204 feet high. It is supported on a wooden pole, 200 feet high. This huge pole about five times as high as the

▲
Doubles signal
without increasing
power
▼

usual telephone pole, is made of three western cedars, spliced together. The concentrator antenna also includes a pole, about 150 feet high, with a vertical copper antenna. The concentrator pole is about 250 feet distant from the exciter and is adjusted to resonate at 1020 kilocycles, KYW's frequency.

Buried in the ground, underneath both poles, is a copper sheet, 14 feet square, with eight strips, running out in a radius of 75 feet. This is a type of ground installation extremely efficient in eliminating ground resistance.

The concentrator tends to bend down the radio waves coming from the exciter, flattening them so that they are intensified over the useful area of the station. In operation, it acts somewhat as a prismatic lens does, encircling a light source, bending down and flattening the light rays, so that they are confined to useful angles near the earth.

By improving the ground wave of the station and decreasing its sky wave, fading is said to have been overcome in the service area of the station. In ex-

plaining fading, engineers state that an antenna system acts like two transmitters, one signal coming from the ground, the other from the sky. If these two signals are about equal in strength, they set up interference, which is known as fading. The same thing may be noted on a radio set, when two stations, on the same frequency, are picked up.

When, however, a ground wave considerably stronger than the sky wave is transmitted, the fading area is pushed out beyond the service area of the station.

By increasing the efficiency of the shorter wavelengths, the concentrator antenna system has made a major contribution to radio. At present the frequency band between 750 to 550 is considered the best. From 990 to 1020 is said to be fair, while most stations violently oppose being placed on the band ranging from 1400 to 1500. With the new system, a station operating at 10 kilowatts, at the higher frequency, has transmitted a signal as powerful as another station operating at 50 kilowatts. There is thus seen the possibility that a wide area of useful wavebands may be opened up, always a desirable thing in the overcrowded broadcast world.

Westinghouse engineers state that the antenna is a comparatively simple matter in installation, with the added difficulties, however, of experimentation and adjustment.

▲ ▲ ▲

Noise Intensity in Radio Reception

By PROFESSOR J. F. BYRNE*

CONTINUING the investigation of radio broadcast transmission conditions, a study of both atmospheric and man-made noise conditions was undertaken during the past summer and fall. The measuring equipment was installed on the grounds of the university's proposed golf course about four miles northwest of the campus.

This study concerned itself only with actual static conditions due to scattered storms. The period of study continued for seven weeks beginning the latter part of July. The observations were made on the average of about ten hours per day, and readings were taken of noise intensity at four different fre-

quencies in the broadcast spectrum. These readings were taken every half hour, making in all a total of approximately 4000 observations. The data show that the noise intensity at the low frequency end of the broadcast spectrum is in the neighborhood of four or five times as great as that at the upper end of the spectrum in daylight hours; while the night-time ratio is approximately $2\frac{1}{2}$ to 1. It is interesting to note that the noise energy received at night is about 2500 times that received on the average quiet day. In addition local storms may cause an increase in noise intensity in a ratio as high as 100,000 to 1, in a period of a few hours.

Further study of this problem is contemplated using an automatic recording mechanism which will not require at-

tention of an operator and will record noise levels continuously instead of at one-half hour intervals. The tabulation of the data already obtained is under way and further information should be forthcoming in the near future.

DESIGN OF RADIO FREQUENCY COILS

In the excellent paper by S. W. Place, page 12, January issue of RADIO ENGINEERING, entitled "Design of Radio-Frequency Coils," the Nagoaka formula, the A^2 and b terms are expressed in centimeters. Mr. Place advises that he neglected to so state in the article.

*Department of Electrical Engineering, Ohio State University.

Antenna transmission line systems for radio reception†

By C. E. BRIGHAM*

IN designing radio receivers radio engineers are careful and anxious to meet the desired characteristics in receiver design. Selectivity, sensitivity and fidelity are three of the most important qualifications which have presented serious problems to every engineer. With the changing of broadcasting conditions, new demands and improvements were necessary in the selectivity, sensitivity and fidelity requirements. Increased sensitivity, whether in tuned-radio-frequency or superheterodyne designs, has presented new problems such as cross-modulation, instability, whistles in superheterodyne reception due to low image ratio response, intermediate-frequency harmonics and reradiation. Increased sensitivity has also resulted in greater noise pickup from man-made interferences, especially in congested metropolitan areas. These are all interference problems to the radio engineer, most of which have been successfully eliminated, with the exception of noise.

With the desire for better fidelity it became necessary to improve the selectivity requirement of a radio receiver in preventing r-f. or i-f. sideband cutting of the higher modulated audio frequencies, by employing band-passed intermediate- and radio-frequency tuned circuits. With the improvements in the reproduction of higher audio frequencies in the speaker greater fidelity of reproduction is realized. In certain important areas, however, the faithful reproduction of high audio frequencies have resulted in serious complaints of noisy reception.

The granting of high power from 20 to 50 kw. by the Federal Radio Commission to a chosen few of the broadcasting stations has hastened the advancement of automatic volume control, or avc, in radio receivers. The automatic volume control development has

been quite remarkable and it is common to experience receivers today holding a constant output on a station of 1000 microvolts field intensity and a station of 500,000 microvolts field strength without changing the position of the volume control. To hold a constant output at these extremely wide variations of input it has become necessary to allow the sensitivity of the receiver to vary automatically over wide limits, such that when no signals are impressed across the antenna and ground the sensitivity of the receiver is naturally high, resulting in serious noise pickup between stations while tuning.

From the foregoing it is seen that in the past few years improvements in the three essential performance features of a radio receiver have led to a type of interference which has only recently been taken into serious consideration by radio engineers. This type of interference is known as "inductive interference" or noise induction from man-made devices. The problems of interference and its elimination have always confronted the radio engineer. Interference from insufficient selectivity, cross-modulation, whistles in superheterodyne reception, have all been satisfactorily eliminated by the development of new circuits, tubes, and by better engineering. Quiet operation and uninterrupted by interference is the ideal requisite of radio performance today. It is evident that today the noise level is being reached in the radio receiving system. The study of inductive interference or noise interference and how it may be eliminated or reduced considerably is the subject of this paper.

Inductive interference in radio receivers is caused by inductive coupling to the receiver system from the noise making devices. Noises in the home are produced from such devices as sparking motors or generators, electric refrigerators, oil burners, electric heating appliances, vacuum cleaners, the shutting on and off of electric lights, violet ray machines and the like. Outside the home some of the most severe sources of noise interference result from high tension power lines, trolley lines, electric elevators, dial telephones, etc.

Noise interference may be introduced into the radio receiver system by four ways:

1. The receiver chassis.

EFFECT ON SENSITIVITY OF ORDINARY SHIELDED LEAD-IN ON LOW IMPEDANCE INPUT RECEIVER

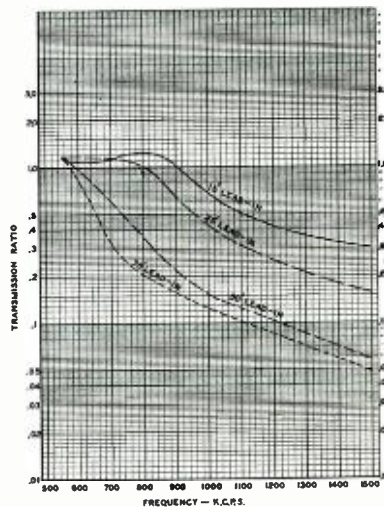

Fig. 2.

2. The power supply system.
3. The antenna.
4. The antenna lead-in.

Of these four, noise interference is the greatest on the antenna lead-in.

Experimentation and experience have shown that little noise interference is being introduced in the present-day receiver chassis, due to its comparatively complete shielding, except from such powerful noise interference devices as the violet ray machine and doctor's or dentist's equipment. It has been found that household noise interfering devices do not radiate at distances much greater than twenty feet, which makes it possible to locate the receiver proper at some point remote from the noise making device. In receivers designed prior to this year, where careful shielding of the radio-frequency and the intermediate-frequency circuits were not employed, noise pickup on the receiver chassis became an important factor. In the receiver chassis of the superheterodyne type it has been found that the radio-frequency grid circuits are much more subject to noise pickup than the intermediate-frequency grid circuits and on the audio system there is very little pickup.

For best results and perfect assurance against noise pickup on the chassis itself complete shielding of the receiver should be employed, including all grid leads, top of grid tube caps and the

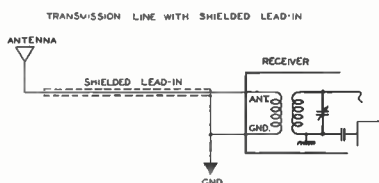
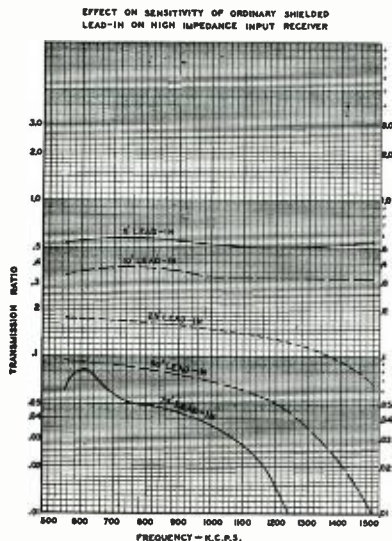

Fig. 1.

†Presented before the Radio Club of America, December 14, 1932.

*Chief Engineer, Kolster Radio, Inc.



antenna and ground leads to the input of the receiver. A test for determining the effect of the completeness of shielding of the receiver chassis parts is to turn the volume control to the maximum position and with the antenna and ground leads free, but not exposed, tune for the local broadcasting stations. If the shielding is effective no broadcasting stations will be heard, or only the very powerful local stations will be heard faintly.

Proper Filtering

Noise from the power supply system is possible if the power supply circuit in the receiver is not properly filtered. A copper shield between the primary and secondary windings, properly grounded to the receiver chassis frame, is found to be an effective filter against both line noises and radio-frequency pickup. A condenser from one side of the a-c. line to ground is another but less effective method of line filter.

The antenna is the second worse offender in picking up noise interference. Next to the antenna lead-in, its position and the way it is installed are of the utmost importance. Unfortunately the public, including radio engineers, have been extremely lax in the installation of antenna systems and much education will be required before full realization is effected in the proper

installation of the antenna for quiet operation and freedom from noise interference. It is extremely important that the antenna be erected outside the source of interference. The location of the antenna is the only limitation in the successful elimination of noise interference. Since the purpose of the antenna is to collect the radio-frequency energy sent out by the broadcasting station and the amount of this energy is determined by the antenna length, its height above nearby obstacles and its distance from the broadcasting station, a long, high outdoor antenna is most essential. An antenna on the roof of any building and especially of a large apartment, hotel, or office building is exposed to a great variety of electrical disturbances. These disturbances are made up of "natural static" and man-made static." Little can be done to suppress natural or atmospheric static, but an efficient antenna system can do much in the elimination of man-made static. The antenna should be at least thirty feet above surrounding obstacles. It is important that the location and direction of the antenna be considered in reducing noise. The antenna should be at right angles to exposed electric light, power or telephone lines and should not cross above or below these lines.

Since the antenna lead-in is necessarily subject to close proximity to the electrical disturbances by having to run near a side of buildings, pass exposed power and telephone lines, and inside of rooms to the input of the radio receiver, it is natural that this lead-in picks up most of the "man-made static" from the electrical disturbances. The problem of shielding this lead-in, without attenuation or losses to the received signal over the wide broadcast frequency range is a very interesting one. This problem today is two-fold since there are two types of input circuits used in receiver designs; the low impedance input and the high impedance input. By low impedance input system is meant an antenna circuit coupled to the first tuned radio-frequency circuit by means of a low impedance inductance of 10 to 50 microhenrys which is naturally periodic above 1500 kc. By high impedance is meant an antenna coupled to the first tuned circuit by means of a high impedance inductance of approximately 3 millihenrys which is

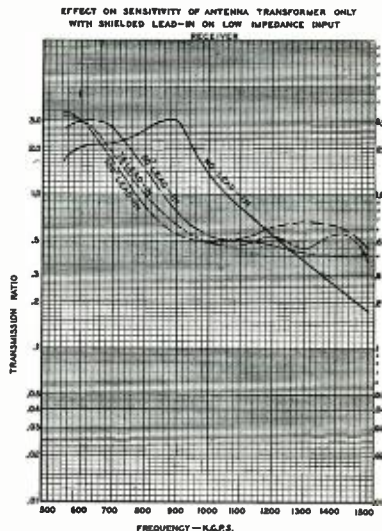

naturally periodic below the broadcast range of 550 kc.

Shielded Lead-In

In the past it has been customary to employ an ordinary shielded lead-in for the elimination of noise on the antenna lead-in, where the lead-in consisted of a single rubber and cotton covered conductor inside a copper braid. This is the simplest type of transmission line system as shown in Fig. 1. The effect of the ordinary shielded lead-in on the sensitivity of the radio receiver of the low impedance type is shown in Fig. 2. The curves are plotted with abscissa covering the broadcast frequency range and the ordinate showing the transmission ratio. By transmission ratio is meant the ratio of the microvolt sensitivity as measured across the antenna and ground of the receiver chassis to the microvolt sensitivity as measured across antenna and ground at the beginning of the transmission line system. It is noticed that serious attenuation becomes effective above 700 kc., increasing with the length of the shielded lead-in, due to the by-passing capacity effect of the lead-in. Attenuation is even much more serious on a high impedance input receiver with the ordinary shielded lead-in wire as shown in Fig. 3. Even five feet of shielded lead-in wire on a high impedance input receiver affects the attenuation in the order of six decibels. Such simple systems usually recommend antenna lengths from 200-400 feet long to make up for the losses in the shielded lead-in. Although effective as far as minimizing noise interference on the antenna lead-in, antenna lengths for the ordinary shielded lead-in became impractical for the complete elimination of noise, especially with the high impedance input receivers.

(To be concluded)

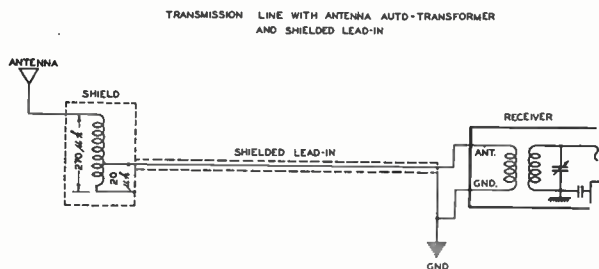

Fig. 4.

A television projector

A RECENT demonstration, in London, of Baird's improved television apparatus, showed a receiver which projected the incoming picture on to a screen four inches wide by nine inches high, the picture being plainly visible to a large number of persons seated within view of the screen.

The images were said to be remarkably free from the line effect hitherto considered as one of the drawbacks in television. In some of the early models the image appeared to be traversed by vertical lines. Since the pictures per second were limited to twelve and a half, a certain amount of flicker was still perceptible, but this cannot be attributed to a defect in the apparatus, and arises simply from the compromise which has to be effected in order to conform to the international sideband limit of nine kilocycles for all television broadcasts on the normal wavelengths used for sound.

A-C. Operated

The whole apparatus is plugged into the commercial lighting circuit, no batteries being required, and it can be operated from any good radio receiving set.

The apparatus differs considerably

from the former Baird model which has been on the market for over two years. Instead of the light metal disc with its series of thirty holes perforated in the metal, and arranged in the form of a spiral near the edge, there is a thirty mirror-drum.

The individually selected mirror, rectangular in shape, is positioned round the drum periphery, being held in place by screws, and so orientated one with another that each is set at a slightly different angle to its predecessor. A beam of light plays on to the drum and is reflected to a screen and built into a series of thirty strips of light in juxtaposition, which together produce a resultant rectangular area, nine inches by four inches.

The neon lamp will continue to function, but a more limited application has, in this model, been replaced by a newly developed form of Kerr cell. Hitherto one of the difficulties in utilizing the Kerr cell has been that very high voltages were required, such voltages making it impossible to turn out a model suitable for home use. By a special patented construction evolved after months of research, this difficulty has, it is said, been overcome.

A small electric lamp of bunched filament construction, and located in the

base at the back of the instrument, sends a beam of light through the Baird grid cell complete with the nicol prisms. The incoming television signals modulate this light beam to conform to the light and shade of the subject situated before the television transmitter. This fluctuating light beam then passes to an inclined mirror positioned inside the casing at the front. From here it is reflected through a lens on to the revolving mirror drum, which in turn "throws" the resultant spot of light on to the front screen, so that the image is built up of strips with the usual light and dark shade formation.

At the left-hand side of the instrument are two switches, one for rendering the lamp incandescent, and the other for establishing connection between the house circuit and the motor. On the same panel is the knob of a rheostat controlling the motor speed. Once the mirror drum has been brought up to approximately 750 revolutions per minute, the automatic synchronizing comes into play and holds the image steady. To allow for incorrect framing and phasing, a knob on the left is available and by turning this slowly the image can be raised or lowered on the screen, or be moved around bodily.

▲ ▲ ▲

An Inter-Carrier Noise Suppression System

(Continued from page 9)

would appear to happen and as would occur with any ordinary type of avc control. Rather, the amplified avc action of this arrangement, as noted previously, is such as to have small effect on weak signals and correspondingly greater control on the stronger signals. So, a desirable amount of control action and full prevention of overloading is accomplished by this new circuit.

It does make a commercial and practical type of noise-suppression without the addition of any more tubes, very little added cost, and none of the service problems which have thus far characterized most of the other forms of suppression.

The input versus output curve shown for this receiver indicates how nicely the avc brings the signals quickly to maximum output level. The four different curves are for four positions of the "sensitivity" control and show how all of the noise below an undesirable level is excluded from the threshold of the receiver.

The r-f., detector and oscillator coils are all of the standard type contained

in separate shields. The two i-f. transformers are tuned to 175 kc. The coils

USE OF THE STANDARD WUNDERLICH A TUBE IN THE B TYPE CIRCUITS

AS the Wunderlich B tube has but recently been introduced, not all radio dealers and jobbers have them available, but the regular A tube is readily procurable through over forty thousand radio dealers throughout the world, and, as many engineers may want to experiment with and employ this newly developed circuit, it was felt to be desirable to work out the same circuits for use with the Wunderlich A tube.

This has just been completed and a practical circuit which utilizes the A tube in the B type of circuit to secure improved detection, delayed avc, amplified avc, and inter-carrier noise suppression, may be procured upon request.

This circuit arrangement will operate with the Wunderlich A tube or with the B tube and the engineer should have no hesitation in using it either way.

have an inductance of 11. mh. and are wound with No. 36 SSE wire. The last secondary may either be center-tapped, or a .5 megohm resistor may be connected from each grid to cathode instead. The condenser from the cathode resistor to ground should be of the paper type. The other two larger units from audio choke to cathode and from audio choke to ground may be of the electrolytic type.

The choke in the filter system can be in either the positive or the negative lead. If the speaker has no tap brought off for negative C bias for the output tube, the same results can be had by using two carbon resistors across the field and tapped as shown in the diagrams.

The constants shown for the various component parts have been carefully evolved in the course of much development work so it is suggested that these values be adhered to. One of the new horizontal type of resonance indicating milliammeters can be used in the plate circuit of the r-f. and i-f. tubes to facilitate in the accurate tuning of the set.

RADIO ENGINEERS TO PARTICIPATE IN ENGINEERING WEEK

PLANS for the conference of engineers at Chicago, during Engineering Week, June 25-30, which is being sponsored by the Century of Progress Exposition, Chicago, are making excellent progress. Radio engineers will be particularly active in connection with meetings of the Institute of Radio Engineers and the American Institute of Electrical Engineers. Some twenty of the national engineering societies will participate with sectional and national meetings.

During the week prior to Engineering Week the American Association for the Advancement of Science meets in Chicago. Many internationally known scientists and engineers will participate on the various programs. Dr. R. A. Millikan is arranging a session on the "Application of Physics to Engineering" which will be a joint meeting of a number of the engineering groups with the International Union of Pure and Applied Physics. This session will begin the activities of Engineering Week, Sunday evening, June 25.

The combined membership of the engineering groups participating in Engineering Week is 91,600. Preliminary estimates of attendance indicate the largest gathering of engineers in history.

RADIO PARTS STANDARDS

TO effect economies in manufacture of radio parts, reducing the number and design of new parts, and simplifying receiving set as well as parts manufacturing problems, over thirty RMA executives and engineers of parts manufacturers participated in a parts standardization meeting recently in Cleveland, Ohio. Leslie F. Muter, of Chicago, chairman of the RMA parts division, presided, and the RMA members began work on standards of many component parts. The meeting was in conjunction with the standards section of the RMA engineering division, of which Virgil M. Graham, of Rochester, New York, is chairman, and followed preliminary organization work, on the parts standardization problem, by Floyd Best, of the Chicago Telephone Supply Company, of Elkhart, Ind., who is chairman of the RMA parts production standards committee.

At the Cleveland meeting group meetings were held by the following group manufacturers: Carbon resistors; wire wound resistors; variable resistors; electrolytic and other fixed condensers; audio coils and transformers, and loudspeakers. The other groups, under their respective chairmen, are arranging for

meetings of all competitors in their lines as soon as possible, and the chairmen will report direct to Mr. Best or Mr. Muter when their standardization recommendations are secured.

The following were appointed chairmen for the different classifications of various units:

Carbon resistors, Dr. S. W. Kelly, Allen-Bradley Co.; wire-wound resistors, H. G. Richter, Electrad, Inc.; variable resistors, E. R. Stoekle, Central Radio Labs.; cabinets, N. P. Bloom, Adler Manufacturing Co.; r-f. coils, J. C. McGinley, Meissner Mfg. Co.; audio and power coils, litz wire, R. T. Pierson, General Cable Co.; transformers and chokes, J. A. Comstock, Acme Electric Mfg. Co.; speakers, T. A. White, Jensen Mfg. Company; variable condensers, M. H. Bennett, Scoville Mfg. Co.; hook-up and conn. wire, R. G. Zendor, Lenz Elec. Mfg. Co.

RUSSIA HAS 59 BROADCASTING STATIONS—OTHERS PLANNED

A POWERFUL radio station, "generating 500 kw." is to start work near Moscow shortly, according to the Tass Agency. A 20 kw. transmitting station at Rostov-on-Don and a 4 kw. station at Lievsk are also to start shortly. The Soviet Union has at present 59 broadcasting stations and the system will be greatly extended in 1933. Several new stations are to be built, many in Russia proper, but it is also intended to construct a 100 kw. station in Minsk (the center of the White Russian Republic) and a station of equal power in Kiev, in the Ukraine.

The Soviet Government, it is stated, intends to erect three new broadcasting stations in Asia. One of them will be at Vladivostock.

RADIO TAX COLLECTIONS

THE seasonal increase in radio sales is reflected in the Treasury's returns from the radio excise tax. The Bureau of Internal Revenue reports radio tax collections of \$218,722 during October as compared with \$165,710 in September. Since the excise tax on radio sets, phonographs, etc., became effective June 20, the Government has received in taxes \$493,727.

TRAVELING RADIO BROADCASTING STATION IN AUSTRALIA

THE Mobile Broadcasting Service Pty., Ltd., with headquarters at 430 Little Collins Street, Melbourne, operates the only traveling broadcasting studio in Australia. The station, with a

call sign of 3YB, has an unmodulated power of 25 watts, giving it an effective radius of fifty miles on a wavelength of 262 meters with a frequency of 1145 kilocycles. The generating and broadcasting equipment is installed in a railway car, together with living quarters for the operator, his wife, and a mechanic. The car is hauled from town to town by freight or passenger trains, working to a definite itinerary. The station operates a "B" class license and obtains its income from broadcasting advertising programs in the country districts.

I. R. E. TO NOMINATE

THE nominations committee of the Institute of Radio Engineers, is at work on the selection of nominees for president, vice-president and three directors, of the national organization.

The nominations are to be presented at the board meeting, early in May.

The members of the nominating committee are W. G. Cady, H. F. Dart, R. A. Heising, F. A. Kolster, Donald McNicol, G. W. Pickard, W. G. White.

OUTSTANDING BROADCAST PROGRAMS

Of the several broadcast programs that are attracting unusual attention, one that is mentioned frequently in a favorable light is that being broadcast at 7:15 p.m., Tuesdays and Fridays from Station CKGW, Toronto, Canada. The broadcast is entitled "The Adventures of Sonny and Sid."

If parents really want wholesome radio entertainment for their boys and girls, they should give these better programs their utmost support—should voice their approval of such program by writing in to the stations carrying them and plainly indicate *why* they like the programs. They might further express their approval of these worthy broadcasts by interesting their children in them—by calling the attention of other parents and children to them. In this way, and in this way only, will programs of the better type for children soon gain right of way on the air.

IMPROVEMENTS RELATING TO ALTERNATING CURRENT FREQUENCY CHANGERS

A TRANSFORMER suitable for use at high frequencies, comprising a ferro-magnetic layer applied to a conducting or insulating layer, the ferro-magnetic layer, which consists of nickel-iron alloy, being stressed to a required degree, by virtue of its associating with the carrier or by auxiliary means.

Telefunken Ges. für Drahtlose Telegraphie, G.m.b.H. British Patent 355,636.

Recent developments in cathode ray tubes and associated apparatus†

By ALLEN B. DUMONT

THE past year has seen a growing interest on the part of engineers in the use of cathode ray tubes for all types of analytical measurements and also for numerous industrial applications. In order to make the cathode ray tube generally more useful it was felt that the life could be considerably improved as well as the uniformity of the tubes. Furthermore any increase in the brilliancy of the spot obtained would facilitate their use in a number of applications. The use of these tubes commercially calls for a tube which is rugged mechanically and which can be operated from equipment which is reasonably foolproof as to adjustment. In this paper it is proposed to discuss the essential characteristics of the cathode ray tubes as well as the essential equipment necessary to operate them.

Tube Characteristics

The requirements of tubes used for oscillograph and allied work may be summarized as follows:

1. They should reproduce with fidelity the observed wave.
2. The threshold effect should be at a minimum.
3. They should give a brilliant spot on the fluorescent screen.
4. The spot should be regular in shape over the entire screen.
5. It should be possible to focus the spot to any desired size.
6. Maximum sensitivity is desirable.
7. There should be a minimum current across the deflection plates.
8. The trace should not blur at high frequencies.

Although special uses may call for more attention to one or more of the preceding requirements if these are met a satisfactory tube for general use will be obtained. Before going into detail on these various points it might be well to mention that experience has shown that a number of screen sizes were necessary. Fig. 1 shows cathode ray

tubes having 2, 3, 5, 7, and 9 inch screens. In order to simplify classification of these various tubes it was decided to designate each tube by a two-number combination the first number representing the diameter of the fluorescent screen and the second numeral the number of deflection plates in the tube. Hence a tube with a 3-inch screen and four deflection plates is known as a type 34 tube and one with a 9-inch screen and no deflection plates is given the type number 90.

Fidelity of Observed Wave

In order to obtain fidelity in the observed wave the deflection plates of each pair should be parallel to each other and the same size. Each pair of deflection plates should be at right angles to one another. The leads supporting the deflection plates should be so positioned that they do not exert any appreciable deflection on the beam. The distance between each pair of deflection plates should be calculated so that the sensitivity is the same along the X and Y axis. This can be obtained by the use of the following formula:

$$h = \frac{EIL}{2E_a d}$$

where

- h = Deflection in cm.
- E = Volts difference between the deflection plates.
- E_a = Accelerating electrode volts.
- l = Length of deflection plates in cm.
- d = Distance between deflection plates in cm.
- L = Length from center of deflection plates to screen in cm.

Hence by having a slightly greater separation between the lower deflection

plates than the upper plates the same sensitivity can be obtained along both axes. It is also important that the screen be smooth and have the same radius of curvature as that of a sphere having its center at the top of the accelerating electrode. In designing the mount which would accomplish the desired results a number of tests showed that by using a suitable mounting jig and assembling all the elements from a common press greater accuracy could be obtained than by taking the connections out separately from the side of the envelope. In the first case after the mount was assembled it could be sealed in without disturbing the elements while in the second case too much responsibility is put upon the glass blower to line up the various elements. Fig. 2 shows tubes with a three and a nine inch screen using this design.

Brilliance of Spot

The brilliance of the spot is determined by a number of factors. Among these are the chemical composition and particle size of the fluorescent screen used. Willemite and calcium tungstate are the two most commonly used salts. The former gives a green color which is probably the best for visual work while the calcium tungstate gives a blue color which is better for photographic work. By using a screen composed of a mixture of these two salts a very satisfactory screen can be obtained which is good for both visual and photographic work. At low accelerating electrode potentials the screen gives a light green color which changes to a white as the accelerating electrode voltage is increased. With the developments in films the importance of the special screen for photographic work is considerably reduced and we have found that by using verichrome film better results can be obtained using a combination screen, than when using calcium tungstate and the older type

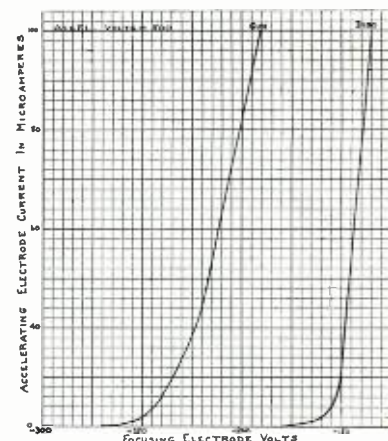

Fig. 3. Focusing electrode bias.

†Presented before the Radio Club of America, January 18, 1933.

films which were quite sensitive in the ultra-violet region but not so sensitive to the longer wavelengths. Generally speaking, the larger the particle size of the salt the more brilliant the spot but, of course, a balance has to be worked out between brilliance and the permissible coarseness or texture of the screen. Some other salts tried with some success are calcium fluoride, phosphorescent calcium sulphate and phosphorescent calcium tungstate. In connection with a particular application calling for the development of a time delay salt we have been able to work out a screen which gives a white spot of from two to three times the brilliancy of any of the screens mentioned. This particular screen is satisfactory for any of the present uses and in addition will retain the trace for as long as one minute and a half after all voltages have been removed when used in a darkened hood or room. However, the spot is so intense that the phosphorescence does not bother the tube when used for any oscillograph application. The phosphorescence itself is bright enough to be readily seen. Another important factor effecting brilliancy is the design of the accelerating electrode. One of the simplest and most effective accelerating electrodes is a disc with a hole in the center placed between the focusing electrode and the bottom set of deflection plates at right angles to the direction of the beam. If the hole is sufficiently large practically the entire beam passes through it and a sharp, well defined spot of excellent brilliancy can be obtained. An accelerating electrode consisting of a cap with a small diameter gun attached to it has proven useful when an extremely fine trace is desired. This construction, however, does not allow all the electrons in the beam to pass

through it, a number being masked off by the cap. The first construction mentioned normally has a current to the accelerating electrode of approximately 30 microamperes, while the last mentioned construction has a current of about 50 microamperes to give the same brilliancy. The characteristic curve of accelerating electrode current versus focusing electrode bias for the two constructions mentioned is shown in Fig. 3. These curves were taken on a type 34 tube with an accelerating voltage of 800. The amount of air or gas in a cathode ray tube also has much to do with the intensity of the spot. Tubes with a considerable amount of gas give a poorly defined spot and low brilliancy. The factors discussed assume that the accelerating electrode voltage was the same in all cases. As this is increased the intensity increases approximately proportionally to the square of the accelerating voltage, since the fluorescent action depends upon the velocity of impact of the electrons onto the fluorescent screen.

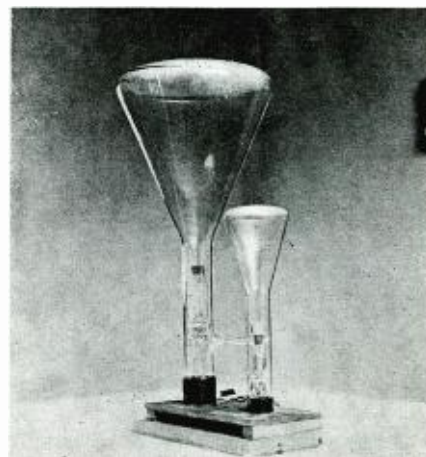

Fig. 2.

Focus

The design of the filament, the shape of the focusing electrode and the pressure inside the envelope are the main points to be considered in connection with focusing the beam of electrons to a point. The spot obtained is the same shape as that of the coated or active part of the filament. The three elements of the cathode ray tube, namely, the filament, focusing electrode and accelerating electrode concerned with the generation, focusing and acceleration of the electrons combine to act in a manner quite similar to that of a pin-hole camera. Hence it is possible to obtain a round spot, a square spot or a spot of any shape depending upon the design of the filament. With reference to the filament the ideal condition is to use a point source of electrons although it is possible to use a large area filament or cathode and concentrate or mask off a portion of the beam to obtain a fine spot. For oscillograph work the focusing electrode is usually in the

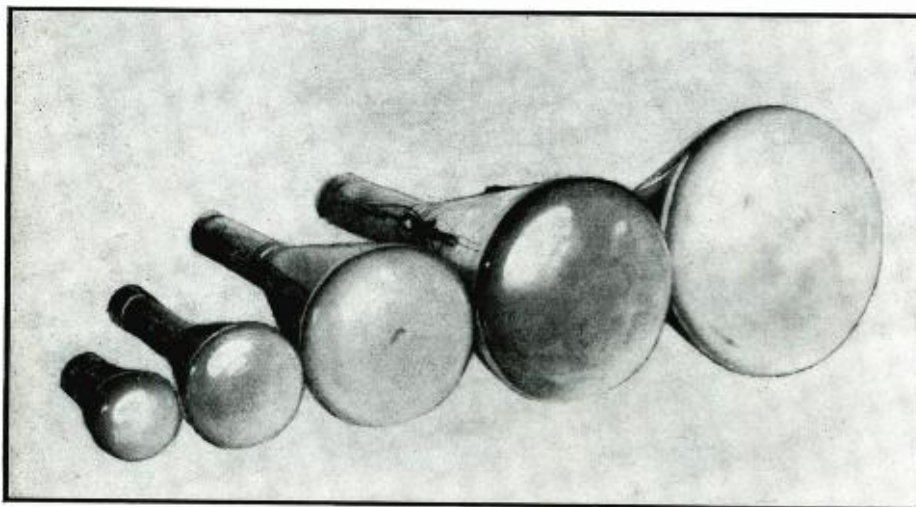
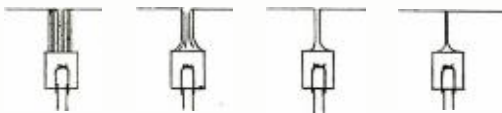

Fig. 1.

form of a cylinder surrounding the filament. Fig. 4 shows how the beam may be concentrated by increasing the bias on this electrode. Fig. 5 is a curve on a type 34 tube which shows the bias necessary to obtain a sharp spot at various accelerating electrode voltages. The function of gas in the tube is two-fold. It provides a path for the charge to leak off the fluorescent screen and it also causes the beam to converge as it approaches the screen. Fig. 6 shows this effect. Fig. 7 shows the beam spread out by the application of an a-c. voltage to the lower set of deflection plates. While on the subject of focusing it might be worthwhile to mention a few things which can affect the sharpness of the spot in ordinary operation.

1. Filament current too high causes halo around spot.
2. Insufficient bias to focusing electrode causes halo around spot.
3. Filament current too low causes large weak spot.
4. Too high a bias on focusing electrode causes large weak spot.
5. A-C. ripple in accelerating electrode voltage supply causes radial line instead of spot as beam is moved from normal center position.
6. Unshielded stray fields cause distortion of spot.



Effect of Gas

Although a certain amount of gas is useful as previously explained, if the pressure exceeds a few microns certain undesirable characteristics come into play. Too high a gas pressure increases the current across the deflection plates. It also limits the frequency at which the tube can be operated. In practice it has been found possible by careful regulation of gas pressure to extend the upper limit of frequency to well over 4 megacycles without having the trace become blurred due to the lateral speed of the beam moving faster than does the ionized gas. Another effect of too high gas pressure is the increase to objectionable proportions of the so-called "threshold effect." That is, the deflection produced by small voltages applied to the deflection plates is not at as great a rate as when higher voltages are applied. Fig. 8 shows the current across the deflection plates versus the deflecting potential, and Fig. 9 shows the curve of beam deflection versus the deflecting potentials. These were taken on a type 34 tube operating with 800 volts on the accelerating electrode.

applications of the cathode ray tube it was soon apparent that no one tube would answer all requirements. To date four different screen sizes have been standardized, namely tubes with 2, 3, 5 and 9 inch screens. The 2 inch screen type is useful for moving film recording where only one set of deflection plates is used, and a number of these can also be used in certain applications to do similar work to the multi-string oscillograph. The three inch screen size type 34, is an economical tube suitable for factory measurements, industrial applications and general laboratory work. The intensity at a given accelerating voltage is somewhat better than the 5 or 9 inch types and because of this, with a given intensity of spot the sensitivity, is approximately the same as with the larger



Fig. 6. Function of gas.

Fig. 7. Beam spread cut by application of voltage to lower plates.

Fig. 5. Curve of type 34 tube, showing bias necessary to obtain a sharp spot at various accelerating electrode voltages.

General

The life of cathode ray tubes has been somewhat of a problem although a large number of tests to determine just what factors determine life have shown that it is entirely practical to design and build these tubes so that consistent and satisfactory life can be obtained when they are operated in suitable equipment. The two major problems have been deterioration of the filament coating by bombardment, and a gradual change in pressure in the tube either caused by the clean-up action of the high voltage or by the liberation of gas from the elements of the tube. The first problem can be eliminated by correct design of the electrodes to reduce positive ion bombardment to a minimum and at the same time use a coating which mechanically withstands this bombardment. The second problem has also been solved by the application of proven vacuum tube exhaust technique.

Because of the wide and dissimilar

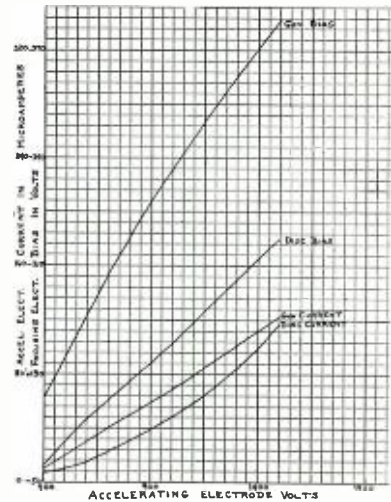

screen types. The larger screen types of necessity must have a longer L value and the slowing up of the beam in the additional distance from the accelerating electrode to the screen accounts for this.

The 5 inch type is mainly used for laboratory determinations where a larger trace is necessary. Certain applications where the tube is used for time interval determinations also require a larger trace. The 9 inch tube has its main use for demonstration purposes although several applications require its exceptionally large screen.

All of the types mentioned can be operated interchangeably from a standard power supply and the prongs of the base fit into a standard six prong socket. The filaments of all tubes consume 1.3 amperes at .6 volt, and heat up in three seconds.

Associated Equipment

In order to realize the full possibilities of the cathode ray tube when used for oscillograph work, it is necessary to provide a power supply which will supply all the required voltages and which is easily adjustable to accommodate the tube to the optimum conditions under test. Although for many applications this is all that is required, a sweep circuit to provide a linear time axis is extremely useful for the accurate study of waveforms and other periodic phenomena. Fig. 10 shows a complete power supply and sweep circuit unit. The power supply being contained in the case nearest the shielded cathode ray tube holder, the sweep circuit contained in the other case.

In Fig. 11 is shown the diagram for the power supply unit. Provision is made for adjusting and checking the filament current. The voltage to the focusing electrode is continuously variable to control the size of the spot, and the voltage to the accelerating electrode is also continuously variable to control

the brilliance of the spot. However, when using voltages on the accelerating electrode, over 1,500, this arrangement is not very practical, and separate rectifiers supply the voltages to the focusing and accelerating electrodes.

The sweep circuit as shown in Fig. 12 provides a linear time axis which may be made to sweep from one to 5,000 cycles per second. The power supply contained in this unit furnishes all the necessary voltages for the sweep circuit except the bias voltage of the mercury vapor discharge tube which is obtained from a standard 4½ volt C battery. The linear sweep frequency is obtained by charging a condenser through a constant-current device. The actual device used is a screen-grid tube operated with the plate voltage well above the screen voltage so that the plate volts versus plate current curve is practically flat over the working region. This arrangement secures not only ease of control (varying grid bias) but also comparative freedom from line voltage variation. The "quick return" discharge is obtained by means of a mercury vapor discharge tube. The use of this tube permits controllable amplitude and ideal synchronization. The unit has the following controls:

1. Position control. A potentiometer arrangement enables the figure to be centered on the screen and moved to any desired position.
2. Amplitude control. The mercury vapor discharge tube flashes at an anode voltage determined by the bias on the grid of this tube. This control varies the grid bias.
3. Frequency control. A fine, and

a rough frequency control are provided. The rough control selects one of five condensers for the plate circuit of the screen-grid tube. The fine adjustment is obtained by varying the bias of the screen-grid tube.

4. Synchronization control. A suitable portion of the voltage of the wave under investigation is fed to the grid of the mercury vapor discharge tube by means of a variable resistance, causing the tube to trip in step with the frequency of the wave under investigation. When this voltage is strictly recurrent a locked or stationary picture is obtained. This control can also be used for tripping a single traverse to record transient phenomena.

It is possible to combine these two units and obtain both the voltage for the cathode ray tube and sweep circuit from one common power supply. However, in this case it is not practical to use as high voltages on the cathode ray tube as with the separate units. Fig. 13 shows one of these combination units. Its main value lies in its portability and it is very satisfactory for all types of visual observations, the limited accelerating voltage, however, somewhat restricts its use for high speed photographic recording.

Classification of Applications of the Cathode Ray Tube

The applications of the cathode ray tube may be roughly grouped into three classifications.

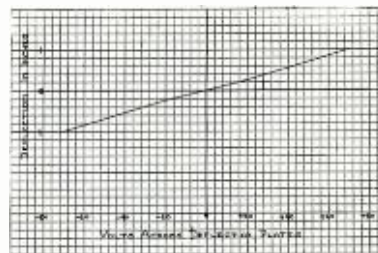

Fig. 9. Beam deflection versus deflection potentials.

1. Applications requiring a time base.
2. Applications not requiring a time base.
3. Applications requiring some independent base other than time.

The applications requiring a time base comprise the general study of waveform. Across one pair of plates is placed a time base potential. This is such as to cause the spot to move forward and backward over a straight line in a known manner. Across the other pair of plates the voltage under investigation is applied. For some purposes a convenient time base is provided by the 60-cycle mains, but more generally the time base makes its excursion at a uniform speed and then restores rapidly. The apparatus described provides this type of a time base.

When the time base is linear the picture or figure that appears is the wave shape of the voltage examined. With a non-linear time base the wave shape is distorted, but if only the middle portion of a sinusoidal time base is used, this distortion is not particularly bad. The method of investigation of wave shape against a time base applies equally to transient as well as periodic phenomena.

Some periodic phenomena which may be studied are:

Waveform studies on alternators, transformers, ripple on d-c. supplies (generators and rectifiers).

Waveform studies of tube oscillators and amplifiers.

Measurement of percentage modulation.

The transient phenomena possible to study include:

Making and breaking of circuits, current and voltage waveforms.

Study of electric sparks.

Static or local interference.

Physiological phenomena such as heart beats or nerve response.

Measurement of explosive and acoustical pressures.

A hybrid case lying between the two groups is the study of the waveform of speech and music and also the case where the voltage takes the form of modulated r-f. In the latter case if the time base is set for observing the lower frequencies the r-f. waveform will be so congested as to give the appearance of a solid figure. The fine structure of

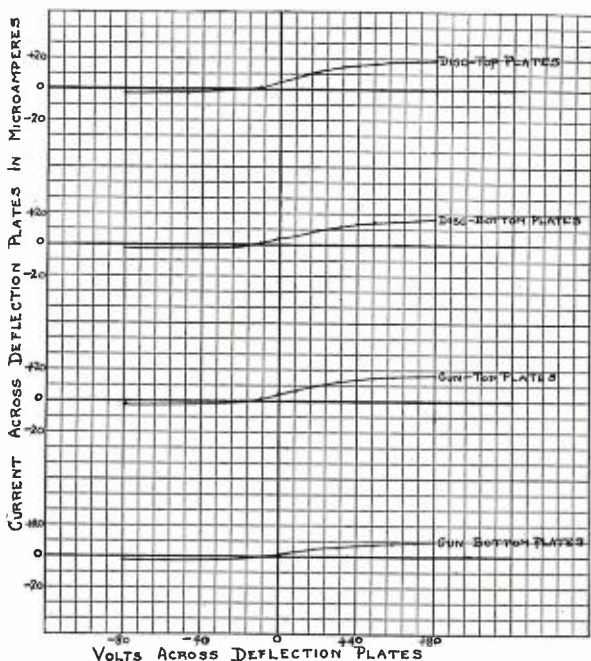

Fig. 8. Current across deflection plates versus deflection potential.

this, however, can be seen by speeding up the time base.

Use of Time Delay Screen

With the new time delay screen it is also possible to readily measure time intervals without the use of a moving film camera. A suitable timing pulse is put across one pair of plates and the focusing voltage biased so no spot is seen. The device or wave to be measured is then connected so that at each impulse the focus bias is decreased so that the spot shows and remains on the screen for about one minute. Hence, the distance between the spots can be measured and the time between pulses determined. In some cases it is desired to measure the time at which certain waves reach given devices and the shape of the wave identified. In this case the voltage of the wave is placed across the other set of deflection plates and the time interval is determined in the same manner as previously.

Another use of the time delay screen is for comparison of given figures. It is possible to put one figure on the screen and then another one over it or in any desired position. With ordinary fluorescent screens it is impossible to see the wave shape of phenomena occurring at rates below approximately one-sixteenth of a second. The time delay screen allows heart beats to be visualized as well as starting curves of motors, etc. In the study of high-speed transient phenomena the present practice is to photograph the transient, as

the eye is not able to retain an impression long enough to arrive at conclusions. The time delay screen permits these to be readily observed.

Applications Not Requiring a Time Base

The applications not requiring a time base include the investigation of current and/or voltage relationships in electrical circuits, wherein both pairs



Fig. 10. Power supply and sweep circuit unit.

of plates derive their deflecting voltages from the circuit itself. Some examples are:

- Observation of tube characteristics either static, dynamic or oscillating.
- Comparison of input and output of amplifiers and transformers.
- Studies of phase relationship.
- Properties of dielectric and magnetic materials.
- Radio direction finding.
- Frequency comparisons.
- Studies of modulation and detection including maintenance and fault-finding on radio transmitters.
- Monitoring on radio broadcasting, talking motion picture and phonograph recording.
- Voltmeter with extraordinary h-f. range. (To be concluded)

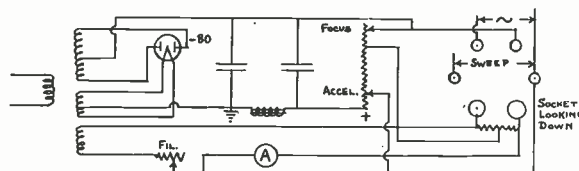

Fig. 11. Diagram of power supply.

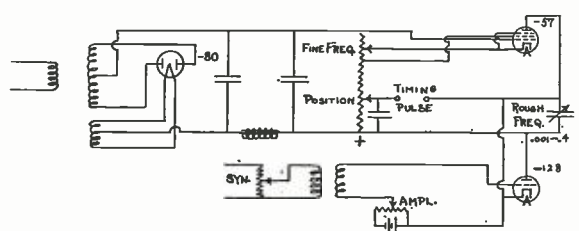

Fig. 12. Diagram of sweep circuit.

Fig. 13. Combination, portable set.

The Hexode Tube

AN outstanding group of inventions which place the combined disadvantages of the superheterodyne principle and automatic volume control within the range of the lowest priced receivers were described in a paper read before the March meeting of the Radio Club of America by Harold A. Wheeler, research engineer of Hazeltine Corporation.

The use of these inventions results in great efficiency and higher conversion gain with one tube and its associated circuits than can now be secured with two separate tubes.

In addition, the development utilized a unique form of coupling between electric circuits. This coupling is brought about through the creation of a cloud of electrons in a space within the network of a highly specialized series of grids contained in a new type of vacuum tube known as the "Hexode."

The cloud of electrons, according to Mr. Wheeler, becomes a "virtual cath-

ode," even though no physical cathode exists in that space.

The new hexode is the first six-electrode tube to be introduced in the radio field, and is the simplest tube structure capable of performing simultaneously the functions: oscillation; modulation, or conversion of the signal to an intermediate frequency; a high degree of amplification, 120 times; and grid-bias control of amplification, required for automatic volume control.

The new hexode is structurally similar to existing screen-grid pentodes, except for the addition of a fourth grid and a redesign of all the grids. The inner three electrodes are used with the oscillator circuits. The electrons which are permitted to pass through the oscillator form a "virtual cathode" between the second and third grids. The variable-mu modulator and amplifier section comprises the virtual cathode and the outer three electrodes. The oscillator acts as a valve to control the emission from the cathode to the virtual cathode and other electrodes, hence this

tube has been named by Mr. Wheeler the "emission valve modulator."

The new hexode makes possible, for the first time, the satisfactory inclusion of automatic volume control in a five-tube a-c-operated superheterodyne receiver.

The earlier circuit developments, which Mr. Wheeler also described, have been in extensive commercial use during the past year and a half. These include the oscillator-modulator circuits developed in the Hazeltine Laboratories which first made possible the 5-tube and 4-tube a-c-operated superheterodyne receivers recently manufactured in large numbers.

By an interesting coincidence these major improvements were presented to the Radio Club of America on the tenth anniversary of the meeting at which Professor Hazeltine demonstrated to the same body one of the first Neutrodyne receivers incorporating his revolutionary inventions which led to the establishment of the Hazeltine Laboratories.

Radio Receiver Design

A statement of the equivalent circuits useful in broadcast receiver design.

By J. E. SMITH*

THE analyses of radio and audio frequency amplifiers, detectors, rectifiers, tube circuits and all transformer designs is very often determined by the use of equivalent circuits.

It is common practice in electrical engineering to simulate the practical design under consideration by an equivalent circuit consisting of the fundamental circuit elements, namely, resistance, inductance and capacity. The proper arrangement of these elements into series, parallel or other combinations and recognizing the resulting impedance characteristics of the circuit as a whole, determines the action and response of such a circuit for any single frequency or for any frequency range.

It is the purpose to show the equivalences of the various circuits which are involved in the design of a complete radio broadcast receiving set. A study of these equivalent circuits enables the designer to visualize more clearly the action of the apparatus and it determines more readily the limitations which are involved.

The Vacuum Tube Circuit

A vacuum tube is generally working into a type of circuit which is shown in Fig. 1. When the grid circuit is held at negative potentials, the grid current is practically zero. The plate circuit is closed through the primary of a transformer and its B supply, and the sec-

*President, National Radio Institute.

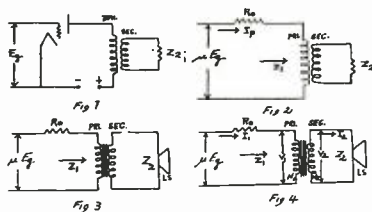

Figs. 1, 2, 3 and 4.

ondary is facing some load impedance Z_2 . Investigating the action of the tube circuit for the simplest case, that is, for a frequency which is not affected by the internal capacities of the tube, we have the familiar relationships shown in Fig. 2.

The plate current in the plate circuit is therefore determined by the relation:

$$I_p = \frac{\mu E_g}{R_o + Z_1} \quad (1)$$

where μ = the amplification factor of the tube.

R_o = the internal plate resistance between the plate and filament of the tube.

Z_1 = the equivalent impedance which the plate circuit faces.

A study of this impedance, Z_1 , will be made for the various circuits under consideration.

The Output Vacuum Tube Circuit

Output transformers which are used in radio broadcast receivers are designed to operate from power tubes which are connected in single, parallel or push-pull circuits. These power tubes supply voltages and currents to the output transformers which are, in general, exciting loudspeakers of the magnetic or electro-dynamic type. The impedance of these loudspeakers varies over a wide range, from a very low value of approximately 4 ohms to a relatively high value of approximately 5000 ohms. The equivalent output circuit for this condition can then be represented as shown in Fig. 3.

In this type of circuit, we are interested in obtaining the maximum power possible from the tube source since power must be delivered to the loudspeaker for its operation. It is known that maximum power will be supplied to the primary of the output transformer when its impedance, with the secondary closed, is equal to the tube impedance R_o . It is also known that for maximum undistorted power to be obtained, it is considered good practice to make the impedance Z_1 about twice the impedance R_o . However, this is not applicable to the pentode type of tube which requires that the relation of Z_1 to R_o be of some higher value.

Let us investigate this circuit further and assume the voltages, currents and turns to be as shown in Fig. 4. Let us assume also that the primary and secondary windings are wound so close together that the coupling between them is perfect. This assumption for the transformers used in practice is acceptable since the coupling and efficiency in the better designs is very nearly 100 per cent. The following relations then hold:

$$V_1 I_1 = V_2 I_2 \therefore \frac{I_2}{I_1} = \frac{V_1}{V_2} \quad (2)$$

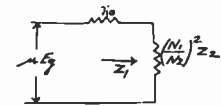

Fig. 5.

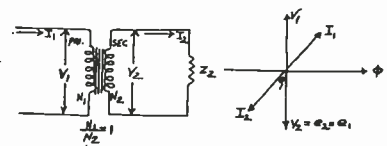

Fig. 6.

- V_1 = impressed voltage.
- V_2 = secondary terminal voltage.
- C_1 = voltage induced in primary.
- C_2 = voltage induced in secondary.

$$\frac{V_1}{V_2} = \frac{N_1}{N_2} \therefore V_2 = \frac{N_2}{N_1} V_1 \quad (3)$$

from (2) and (3)

$$\frac{I_2}{I_1} = \frac{N_1}{N_2} \quad (4)$$

$$V_2 = I_2 Z_2 \quad (5)$$

from the above

$$\frac{V_1}{N_1} \frac{N_2}{N_1} = \frac{I_1 N_1 Z_2}{N_2} \therefore \frac{V_1}{I_1} = Z_1 = \frac{(N_1)^2}{(N_2)^2} Z_2 \quad (6)$$

The above relation for Z_1 is a very important one on the design of output transformers. The equivalent impedance which the plate circuit faces is therefore impressed by the above relation (6) in terms of the turns ratio of the transformer and the impedance of the load. It follows that if the plate resistance R_o is equal to 2000 ohms and the loudspeaker impedance Z_2 is equal to 4000 ohms, the turns ratio for the output transformer will be expressed by the following equation:

$$\frac{N_1}{N_2} = \sqrt{\frac{Z_1}{Z_2}} \quad (7)$$

If the design of the transformer is to be such that the impedance Z_1 is to be twice the impedance R_o , the turns ratio will then be expressed by the following equation:

$$\frac{N_1}{N_2} = \sqrt{\frac{4000}{4000}} = 1 \quad (8)$$

The primary turns will therefore have the same number of turns as the

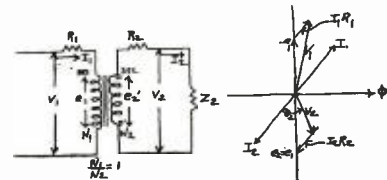

Fig. 7.

- R_1 = resistance component of primary winding.
- R_2 = resistance component of secondary winding.

secondary, and a one-to-one ratio transformer will be used.

The equivalent circuit of Fig. 4 can then be replaced by that of Fig. 5. In the actual case, we do not have as simple an equivalent circuit as shown in Fig. 5 because there is a small leakage magnetic flux which exists in the transformer and there are distributed capacities in the primary and secondary windings. These affect the response at the higher frequencies, and due consideration must be given them.

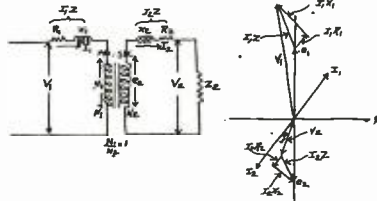

Fig. 8.

- R_1 = resistance component of primary winding.
- R_2 = resistance component of secondary winding.
- X_1 = reactance component of primary winding.
- X_2 = reactance component of secondary winding.

Vector Diagrams of the Transformer

A study of the leakage, capacity and resistance effects of a transformer which produce the equivalent circuits can be readily investigated by the use of vector diagrams. Such a diagram for the ideal transformer is shown in Fig. 6.

This diagram is explained as follows: A voltage V_1 applied to the primary of the transformer induces a flux ϕ in the core. This magnetic flux cuts the turns of both the primary and secondary windings and induces voltages e_2 and e_1 in them. From the law of magnetic induction, this induced voltage will be opposite in phase to the impressed voltage. The load impedance Z_2 in this diagram is taken as inductive, and thus the current I_2 will lag the secondary voltage V_2 by an angle θ_2 .

When resistances are present in the primary and secondary windings of the transformer, the vector diagram for this condition is shown in Fig. 7. With the load Z_2 taken again as inductive, the current I_2 will lag the secondary voltage V_2 by an angle θ_2 . Under this condition, it is expected that the secondary terminal voltage V_2 will be some value less than the induced voltage e_2 because there is a resistance drop in the secondary winding. This resistance drop in the secondary, $I_2 R_2$, will be in phase with the secondary current I_2 , and the terminal voltage V_2 will be determined from the triangle of the vector voltages e_2 and $I_2 R_2$. Now, it is expected that the impressed voltage V_1 will be some

value greater than the induced voltage e_1 , in that winding, because there is a resistance drop in the primary winding. The resistance drop, $I_1 R_1$, will be in phase with the primary current I_1 and the impressed voltage V_1 will be the vector sum of the drops around the primary circuit.

When the leakage reactance of both primary and secondary windings, as well as the resistances, are taken into consideration, the vector diagram is as shown in Fig. 8.

Under these conditions, this diagram is explained as follows: With the load Z_2 inductive, the current I_2 will lag the secondary voltage V_2 by an angle θ_2 . Now the secondary terminal voltage V_2 will be determined by the vector resultant of the $I_2 X_2$ and $I_2 R_2$ drops ($I_2 Z$) and the induced voltage e_2 . Here, the resistance drop $I_2 R_2$ is in phase with the secondary current I_2 and the reactance drop $I_2 X_2$ is at right angles to it. The vector V_2 is therefore the vector sum of e_2 and $I_2 Z$ as shown in Fig. 8. The primary impressed voltage V_1 will be determined by the vector resultant of the $I_1 R_1$ and $I_1 X_1$ drops ($I_1 Z$) and the induced voltage $-e_1$. The vector V_1 is therefore the

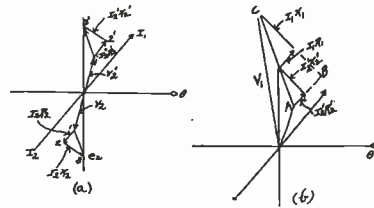

Fig. 9.

vector sum of $-e_1$, and $I_1 Z$ as shown in the figure. Now, we are in a position of showing the possibility of transferring the voltage vectors of the secondary circuit into the primary circuit. It is expected that these will appear in the primary circuit in an opposite phase and in magnitude which is dependent upon the turns ratio of the primary and secondary windings. With reference to Fig. 9 (a), the triangle of secondary

voltage drops (1-2-3) will now appear in the primary circuit as (1'-2'-3'). Here the $I_2 R_2$ and $I_2 X_2$, the resistance and reactance drops respectively of the secondary circuit, will appear in opposite phase as $I_2' R_2'$ and $I_2' X_2'$. The magnitude of these vectors will be the same because the turns ratio of the transformer has been taken equal to 1. It is noticed from Fig. 9 (b) that these drops are in phase with the respective resistance and reactance drops $I_1 R_1$ and $I_1 X_1$ of the primary circuit and therefore can be directly added to the primary circuit. A figure A B C can therefore be drawn which shows directly the combined equivalent resistance and reactance drops of the two windings, referred to the primary circuit.

The following relations are apparent from Fig. 9 (b).

1. The total resistance drop referred to the primary side is:

$$I_1 R_t = I_1 R_1 + I_2 R_2 \left(\frac{N_1}{N_2} \right)$$

Since $I_1 N_1 = I_2 N_2$; $I_2 = I_1 \left(\frac{N_1}{N_2} \right)$

Substituting the above value of I_2 in the first equation:

$$I_1 R_t = I_1 R_1 + I_1 R_2 \left(\frac{N_1}{N_2} \right)^2 \quad \text{or}$$

$$I_1 R_t = I_1 \left[R_1 + R_2 \left(\frac{N_1}{N_2} \right)^2 \right]$$

Therefore, the equivalent resistance R_t of a transformer referred to the primary circuit is:

$$R_t = R_1 + R_2 \left(\frac{N_1}{N_2} \right)^2$$

2. The total reactance drop referred to the primary side is, by the same reasoning:

$$X_t = X_1 + X_2 \left(\frac{N_1}{N_2} \right)^2$$

The above relations are very impor-

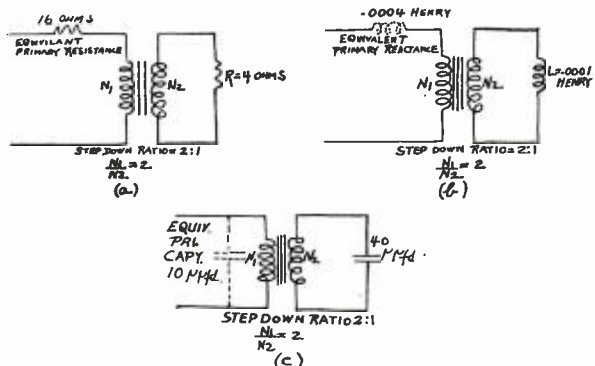

Fig. 10.

tant in the study of the equivalent circuits which are used in radio. These relations show that resistances, inductances, and capacities in the secondary circuit can be referred to the primary circuit as follows:

1. A resistance R in the secondary circuit will appear in the primary as

$$R \left(\frac{N_1}{N_2} \right)^2 \text{ See Fig. 10 (a).}$$

2. An inductance L in the secondary circuit will appear in the primary as

$$L \left(\frac{N_1}{N_2} \right)^2 \text{ See Fig. 10 (b).}$$

3. A capacity C in the secondary circuit will appear in the primary as $C \left(\frac{N_2}{N_1} \right)^2$

See Fig. 10 (c).

(a) This follows from the fact that the capacity is inversely proportional to the reactance.

The Equivalent Output Vacuum Tube Circuit

Let us investigate the output circuit of a vacuum tube which is working into a dynamic type of loudspeaker shown

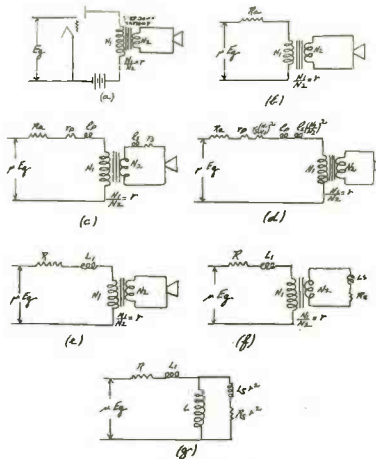

Fig. 11.

in Fig. 11 (a).

With the internal resistance of the tube equal to R_v and the amplification factor equal to μ , the equivalent circuit of Fig. 11 (a) becomes that of Fig. 11 (b).

With resistances r_p and r_s and leakage reactances l_p and l_s in the primary and secondary windings of the trans-

former, respectively, the circuit is represented by Fig. 11 (c).

With the secondary resistances and reactances of Fig. 11 (c) transferred to the primary circuit, Fig. 11 (d) is obtained. Let the resistances be combined with R_v and the total leakage reactance be represented by L_p , and the circuit will be shown in Fig. 11 (e).

The loudspeaker circuit can be represented by a resistance and inductance in series. The inductance L_s of Fig. 11 (f) represents the windings of the loudspeaker and the resistance R_s corresponds to both the resistance of the windings and to the power consumed in the mechanical operation of the loudspeaker.

The complete equivalent output vacuum tube circuit is represented in Fig. 11 (g). The inductance and resistance of the loudspeaker is referred to the primary circuit across an inductance L which represents the primary winding of the transformer.

All the constants in the circuit of Fig. 11 (g) can be obtained and computations can be made which will show the magnitude of the currents and voltages which exists at various frequencies.



Tubes for Automobile Radio

By ROGER WISE*

FROM the time of the development of the early portable loop receivers, automobile radio has been visualized by pioneer engineers and experimenters as having far-reaching and important possibilities for commercial exploitation. The obstacles to success have been unusually numerous, and it is not surprising that only during the current season has the volume of sales of automobile receivers been more than a drop in the bucket when compared with that of household sets. Currently the increasing importance of this development is well recognized, and almost without exception radio manufacturers who have not as yet manufactured a receiver for this service are giving it serious consideration.

Two years ago there was no agreement as to what types of tubes should be used for automobile service, none of the standard types then available being satisfactory. A survey of the requirements led Sylvania engineers to the conclusion that the best way to meet this condition was to take advantage of progress made in tube development and to provide new tools for the job by the development of special tubes. This work was done in 1930, and in January, 1931,

*Chief Tube Engineer, Hygrade Sylvania Corporation.

several automobile tubes were described by the writer. These tubes incorporated the following important features:

1. All tubes were of the heater type, designed to operate directly from a 6-volt battery subject to the wide fluctuations in battery voltage occurring in automobile service.

2. Efficiency was high; heater current and wattage was less than half that of earlier cathode type tubes, yet the mutual conductance was maintained at a high level.

3. Microphonism previously experienced with filament type tubes, and a service factor because of vibration, was eliminated.

Having made these tubes available to manufacturers, they were kept up-to-date by constant engineering and production refinements. Every comment made by manufacturers was given careful consideration and changes made when needed to secure improved performance. New types were added as required for improved design until the line was as complete as that of the 2.5 volt group. About this time cost became a factor of great importance, and since increased volume afforded the best possibility for progress, tests were made to determine whether or not the tubes could be adapted to service in household

receivers. A few minor changes were made and additional power output tubes developed, tests then showing that all requirements for this service had been met. Added volume and improved production methods then quickly reduced the costs to figures below those of previous a-c. tube types, and quotations to manufacturers were adjusted accordingly.

The production of tubes for automobile service and utilization of these same tubes in household sets is no longer in the experimental stage, as evidenced by the very large number of tubes in service, by favorable production records (cost and shrinkage), and by equally good quality and life test reports.

RMA TALKS OF NEW DESIGNS

MANY industry leaders are planning to attend, March 20, a meeting at the White Hotel in New York, by the National Alliance of Art and Industry to consider changes in receiving set design, to stimulate sales. National merchandising leaders will address the conference.

Development of an entirely new style, or type, of receiving set design, radically different from the general console and midget models, is being given serious consideration by radio industry leaders.

Samson Electric, Inc.
Canton Mass.

(R. W. Cotton, Vice-Pres.)

a subsidiary of.

S. H. Couch Co., Inc.
North Quincy Mass.

(MANUFACTURERS OF TELEPHONES and ELECTRICAL SPECIALITIES FOR FORTY YEARS)

is pleased to announce that they have purchased the assets, including goodwill, patents, trade marks, company names, etc., of the Samson Electric Co., Canton, Mass., and will continue to engineer, manufacture and offer for sale the individual products and complete electrical sound systems of the former Samson Electric Co.



NEWS OF THE INDUSTRY

ARCTURUS APPOINTS NEW CHIEF ENGINEER

The Arcturus Radio Tube Company, Newark, N. J., announces the appointment of John J. Glauber, M. E., as chief engineer. Having been with Arcturus since its early days, Mr. Glauber has developed many of the new tubes pioneered by that company.

A graduate of Stevens Institute of Technology, Mr. Glauber has had extensive experience in the radio and mechanical fields.



J. J. Glauber

After a short career in the laboratory of the U. S. Tool Company, he entered radio in its early days. For the last five years he has been with the Arcturus as assistant chief engineer.

Mr. Glauber has been an enthusiastic licensed amateur since 1919. He has addressed many engineering meetings, one of the most important being the presentation of a paper, "The Application of the Screen-Grid Tube in A-F Amplifiers," before the Radio Club of America, in the days when the screen-grid tube was a vision.

Through his extensive contact with set manufacturers, having visited most important plants, Mr. Glauber is well versed in receiver and circuit design and in their problems. This comprehensive experience will abet his tube training in being helpful to manufacturers in adapting new tubes in their receivers.

ELECTROLYTIC CONDENSERS

The new Acracon electrolytic condensers manufactured by the Condenser Corp. of America, 259 Cornelison Ave., Jersey City, N. J., are meeting with popularity in the radio manufacturing field. There are semi-dry units in round aluminum, cardboard and metal filter types. Also by-pass condensers for replacement use.

HYGRADE-SYLVANIA

H. M. Abbott, sales manager of the lamp division of Hygrade-Sylvania Company, is now also in charge of radio sales for that company.

▲ TONE COMPENSATION

The success achieved by using the tapped Bradleyometer is attested by radio receiver quality being sustained at low as well as high levels. This modern volume control is manufactured by the Allen-Bradley Company, 126 W. Greenfield Ave., Milwaukee, Wisc.

▲ MODERN CABINET AND CHASSIS ASSEMBLY

The hardened self-tapping sheet metal screws for making fastenings to sheet metal up to 6 gage, aluminum, die castings, Bakelite, etc., and hardened metallic drive screws for making permanent fastenings to iron, brass, aluminum castings, steel, Bakelite, etc., are now universally adopted by manufacturers of both large and small radio receivers. They are manufactured by the Parker-Kalon Company, 190-198 Varick St., New York.

▲ AUDIO TRANSFORMERS

The poor performance and short useful life of certain types and makes of audio amplifiers during the past few years has been discovered to be due largely to improperly designed, cheap transformers.

Transformers which meet the specifications of radio engineers are manufactured by the Thordarson Electric Mfg. Co., 500 West Huron St., Chicago, Ills.

The company announces transformers designed particularly for correct use with the new vacuum tubes now being announced.



J. M. SMITH AND J. C. WARNER APPOINTED VICE-PRESIDENTS OF RCA RADIOTRON

E. T. Cunningham, president of RCA Radiotron Company, Inc., has announced the appointment by the board of directors of J. M. Smith and J. C. Warner as vice-presidents of the corporation.

Mr. Smith heads the manufacturing organization. He has been engaged in manufacturing radio tubes since he joined the General Electric Company at Nela Park in 1914. He became associated with the RCA Radiotron Company as manager of the Ivanhoe Works (Cleveland), upon the formation of the company in 1930. A native of Ohio, Mr. Smith was graduated from Bethany College, in West Virginia.

Mr. Warner has been in charge of the research and development laboratory of RCA Radiotron Company since 1931. He was born in Freeport, Illinois, and holds a B. A. degree from Washburn College, an M. A. degree from the University of Kansas, and an M. S. degree in electrical engineering from Union College. He was a member of the Signal Corps during the war, taught physics at the University of Kansas, and was assistant physicist in the Bureau of Standards. From 1920 to 1931 he was engaged in research work and vacuum tube engineering for the General Electric Company.



J. C. Warner

J. M. Smith

SALES FIGURES

PROVE MORE

MANUFACTURERS

THAN EVER NOW

SPECIFY "ACRACON"

CONDENSERS

A TYPE for EVERY NEED:

- ELECTROLYTIC
(WET OR SEMI-DRY)
- BY-PASS
- "MIKES"
(MIDGET TUBULAR UNITS)
- AUTO GENERATOR UNITS
(FOR AUTO RADIOS)

Write Today for 1933 CATALOG and PRICE LIST!

CONDENSER CORP. of AMERICA

259 Cornelison Ave., Jersey City, N. J.

Factory Representatives In:

Chicago Cincinnati St. Louis San Francisco

Los Angeles Toronto

And Other Principal Cities

Patents pending on all Acracon features.

BUILT TO STAND UP

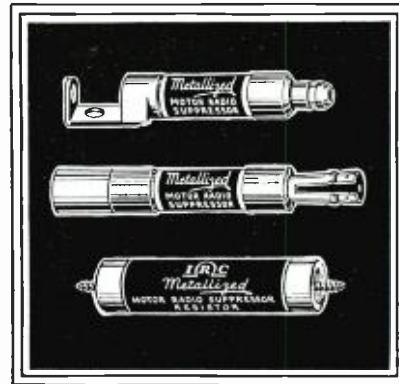

MOTOR RADIO SUPPRESSORS

Freezing weather, intense heat, grease deposits, steam, severe stress or vibration—any of the unfavorable elements of motor car operation — hold no terror for IRC Motor Radio Suppressors. Not only are they designed to eliminate *all* motor noise but to do it effectively under the most adverse operating conditions.

Study these points of IRC superiority:

ONE-PIECE CONSTRUCTION

IRC Suppressor terminals are of rugged one-piece construction, locked and keyed in position by casting them in metal. Spark suppressor lug and screw are in one-piece as is the distributor suppressor. No riveting, no cement or solder, no loose springs or other parts. *IRC terminals will not loosen under the most severe vibration or stress.*

MOISTURE-PROOF

There are no parts in IRC Suppressors which can be mechanically changed by moisture—no cement to be softened by high humidity. A special moisture proofing guards against electrical changes.

LOW RESISTANCE CONTACT

Electrical contact is made DIRECT from the one-piece terminal to the resistor element. There are no springs, steel wool or other intermediate elements to corrode or soften and cause imperfect contact. Also, IRC resistor ends are so treated that unusually low resistance contact is obtained between terminal and resistor element. Thus sparking under high ignition voltages is avoided.

HEAT RESISTANT

IRC Suppressors have a low temperature coefficient and are not affected by heat resulting from proximity to hot motor parts.

NOISE SUPPRESSION EFFICIENCY

Exceedingly low capacity—less than 1/2 micro-microfarad—makes IRC Suppressors meet the most exacting requirements for absolute suppression of ALL motor noise.

A wide variety of laboratory and actual car operation tests have given many additional facts regarding IRC superiority. We'll gladly send them to radio engineers on request.

INTERNATIONAL RESISTANCE CO.

2006 CHESTNUT STREET

PHILADELPHIA, PA.

In Canada, 74 Wellington St., W., Toronto, Ont.

NEW DEVELOPMENTS OF THE MONTH

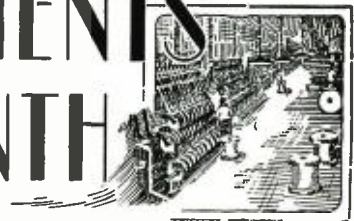

SPEEDCRAFT WIRE STRIPPER

The Wire Stripper Co., Cleveland, Ohio, have just placed on the market an improved model of their knife type Speedcraft wire stripper.

This production machine handles about 90 per cent. of all wire stripping operations. Special features of this improved stripper are the interchangeable guide bushings and the positive action knives.



The bushings hold the wire in correct position so that all the insulation is cleanly removed without in any way harming the copper. The machine is especially effective on small gauge wire—even when insulated with a single or double cotton, or paper tape.

This model Speedcraft is somewhat simpler in design and action than the old style machine. It is sold at a considerable reduction in price.

The manufacturers have just issued a new folder which fully describes this Speedcraft stripper as well as the other wire stripping equipment which they make.

R-F. AND I-F. COILS FOR MINIATURE RECEIVERS

There have been rapid developments in radio-frequency coils and i-f. units during the past season. However, most of the developments have centered around different combinations or assemblies of standard coils and windings. At the present time is announced to the radio industry an entirely new winding for broadcast purposes. Such a winding for commercial long-wave use has been employed, but its adaption to the broadcast band for mass production of radio receivers is an entry into a new field.

Until the present time the lattice wound coils have been the only available type of winding to meet the pressing demands for extremely small coils for the present day miniature sets, which type of winding although answering this purpose has not proved entirely satisfactory in view of the extremely low gain and distributive capacity.

The RFB No. 4, as the new four-bank winding is designated, although extremely small in physical dimensions, is in no way a sacrifice of efficiency, and

compares favorably with all coils regardless of size. At 600 k-c. the interstage coil, when measured in a single stage gain test with a number 58 tube, proved a gain of 110 times input, and at 1,500 k-c., a gain of 65 times input. Although the above figures are given for the limits of the broadcast band only, this coil when properly balanced with any of the present standard low minimum variable condensers has an extended frequency coverage even beyond 540 and 1,700 k-c. in most instances.

This winding has an adaptation for r-f. and superheterodyne requirements, and is at the present time being supplied in volume for miniature a-c. and d-c. receivers of the tuned radio-frequency type, generally in sets of two consisting of an antenna and an interstage coil of high impedance construction, supplying a flat amplification curve and a most satisfactory sensitivity response. Manufactured by General Mfg. Co., 8066 S. Chicago Ave., Chicago, Ill.

NEW SLIDE WIRE RHEOSTAT

A small, high quality, inexpensive slide wire rheostat for servicemen and manufacturers of electrical equipment is announced by G-M Laboratories, Inc., 1735 Belmont Ave., Chicago, in their type R rheostat. Wound on a one-piece porcelain form, with adjustable contact for varying the resistance, this unit is designed for maximum service and convenience. It will dissipate 75 watts continuously.

These rheostats are wound with wire having low temperature coefficient of resistance, and can be supplied in 12 ratings from 5,000 ohms, 0.12 ampere to 4.8 ohms,



4 amperes. The price of these rheostats is said to be exceedingly attractive, particularly so in their special kit assortment comprising 6 rheostats of different ratings.

Binding screws at each end of the winding permit the use of any type R rheostat as a potentiometer.

"B" ELIMINATOR

This Airline "B" eliminator is designed to be operated from a 32 volt light plant system. The eliminator is so arranged that it will operate practically all radio sets that formerly used 2, 3, or 4 "B" batteries.

The eliminator is of the rotary type—that is, driven by a small motor. This motor has been designed with ball-bearings and a permanent oiling system, thereby eliminating the necessity for oiling at any time. No provisions are made for oiling

or lubrication. With ordinary usage, this eliminator will last as long as your radio set.

The eliminator is arranged so that it can be placed either near the radio set, or if the set is a console, it can be installed in the cabinet, or it can be located at a distant point, such as a clothes closet,



basement, etc. While the eliminator has been designed to give extremely quiet operation, some of the mechanical noise due to the motor cannot be entirely eliminated, therefore many of our customers find it advisable to locate the eliminator at a distant point where this slight mechanical or motor noise would not be objectionable. A 12 foot cord is provided for this purpose. If the 12 foot cord is not sufficient, ordinary wire can be added making sure that the connections are well soldered and taped.

An 8 foot connecting cord with connection plug is supplied to plug in the light socket on a 32 volt lighting system. This should be plugged in either a light socket or a wall plug. The cord is provided with a switch so that the eliminator can be turned on and off conveniently.

Manufactured by Carter Genemotor Corp., 361-365 W. Superior St., Chicago, Ill.

RESISTORS FOR A-C.—D-C. SETS

D. T. Siegel, general manager, Ohmite Manufacturing Company, 636 N. Albany Ave., Chicago, announces that this company is now manufacturing a new type of resistance unit for use on a-c.-d-c. radio sets which eliminates from the set the heat produced by the voltage reduction needed for the tube filaments.

This resistor, known as the Cordohm, is being manufactured under exclusive license from the Stewart-Warner Corporation. The unit which looks much like the ordinary lamp cord, consists of three wires, two copper and one resistance wire, all wound in the same cord. The two copper wires furnish the 110-volt circuit and the resistance wire lead furnishes reduced voltage for the filament circuit. One end of the unit is connected to a soft rubber connection plug.

200-VOLT BYPASS CONDENSERS

A low voltage bypass condenser, type EB, for radio and audio frequencies, in an inverted drawn metal case, is manufactured by Wego Condensers, Inc., 729 Seventh Ave., New York City.

Transformers for Class B amplification in broadcast transmitters



Output transformer for use between push-pull, class "B" stage using 204-type tubes and a class "C" amplifier. Operating level + 50dB; primary 1500 1500 ohms; secondary 4750 ohms; tested at 15,000 volts; oil insulated.

FOR six months AmerTran engineers have been studying all problems associated with Class B Amplifiers. With this experience as a background a complete line of audio-frequency transformers (input and output) has been especially designed for use with tubes suitable for Class B operation.

Large output transformers for use in Class B Amplifiers of broadcast transmitters are of the design illustrated above and have the following features:

1. Oil immersed with Isolantite bushings. This permits insulation testing at a voltage which is considerably in excess of any peak which might be experienced in actual practice.
2. Welded aluminum tank provides complete r.f. shielding.
3. Wire used in primary and secondary windings is of a size which insures low d.c. resistance and ample current capacity.
4. Primary sections are balanced within 0.5% and the same phase angle exists in each section.
5. Core laminations of the best quality high-permeability alloy are operated at a low density.
6. Coil structure insures low distributed capacity, low capacity coupling, and high inductance coupling.
7. High efficiency insured by excellent regulation, constant input impedance, and unusually satisfactory frequency characteristics throughout the band of 30 to 10,000 cycles.

Complete information on transformers for use with a specific type of tube will be mailed promptly on request.

AMERICAN TRANSFORMER COMPANY
180 Emmet Street Newark, N. J.

The AmerTran line includes transformers of every description for audio amplification and radio transmission.

AMERTRAN

Audio Transformers

STACKPOLE Announces—

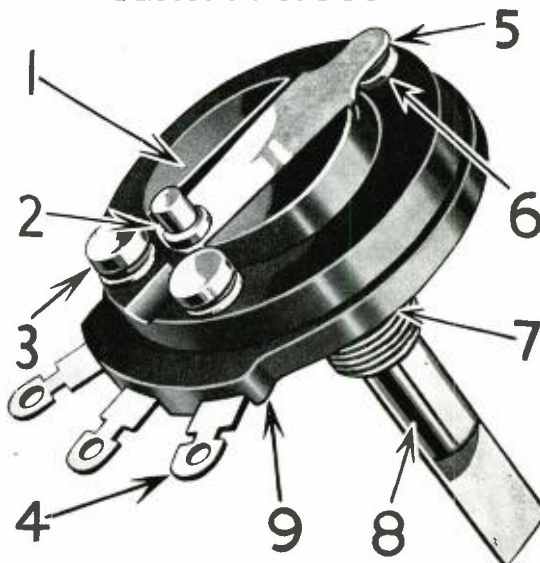

A New, Improved Type of Molded Carbon Volume Control

- 1) INSULATED BUSHING AND SHAFT. This bakelite hub carries the spring arm and the contact for the moving element and the shaft is molded into the other end of this bakelite hub, so the mounting bushing and shaft are fully insulated from the entire control resistor.
- 2) SWITCH OPERATING CAM. The cam dog which operates the a.c. switch on the switch type variable resistors, is assembled as a composite part of the moving arm member assuring accurate operation of the switch in respect to the resistance curve or hop-off value.
- 3) RUGGED STOP PINS. These rugged stop pins are accurately located through the resistor element and the bakelite frame and hold the entire assembly into one solid form.
- 4) LUGS EASY TO SOLDER TO. The three lugs on the variable resistor, as well as the two on the a.c. switch, are tin dipped to make it very easy to solder the connecting wires to them.
- 5) CONSTANT SPRING TENSION. The exact amount of downward tension is always maintained on the rotating shoe by this one-piece, special tempered spring arm.
- 6) SMOOTH ACTION—ABSENCE OF NOISE. This nickel chrome sliding shoe is highly polished, cannot corrode and assures smooth and easy rotation of the arm of the variable resistor.
- 7) STANDARD ONE-HOLE MOUNTING. The standard 3/8" brass bushing is fully insulated from the arm and resistor element.
- 8) NON-RUSTING SHAFT. This shaft is of cadmium plated steel and fits perfectly in the bored brass bushing to provide smooth and quiet operation.
- 9) MOLDED CARBON RESISTOR ELEMENT on bakelite frame. The thick molded carbon resistor element is made much like the permanent carbon resistors and is fired at high temperatures, resulting in a hard, glass-like surface impervious to temperature, humidity and hard usage. Made in any value from a few hundred ohms to a couple of megohms with any desired resistance taper and any hop-off or fixed value of resistance at either or both ends. It is the first control of its type and the first compact variable resistor which is Permanent, Unaffected by Humidity, Will Carry Considerable Current, Free of Capacity Effect, Smooth and Quiet in Any Circuit, and having Low Heat and Voltage Coefficient.

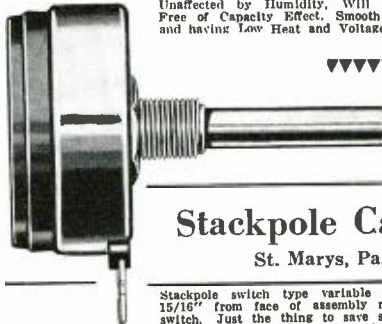

Stackpole Carbon Co.

St. Marys, Pa., U. S. A.

Stackpole switch type variable control shown here is only 15/16" from face of assembly nut to the rear of the AC switch. Just the thing to save space in the new ac-de small chassis. Can be supplied with very short mounting bushing to save further space and any length of shaft.

NOW!
\$100
 PROTECTION GUARANTY
 TO YOUR INSTRUMENTS WHEN
 PROTECTED BY
LITTELFUSES



LITTELFUSES will positively protect your meters, radios, tube testers, etc. Stock sizes 1/100, 1/32, 1/16, 1/8, 1/4, 3/8, 1/2, 3/4, 1, 1-1/2, 2 amps. capacities.

LITTELFUSES are also made in 1000-, 5000- and 10,000-volt ranges.

Write for New Cat. No. 5 complete details
 LITTELFUSE LABS., 1782 Wilson Ave., Chicago, Ill.

REMLER REMOTE CONTROL AMPLIFIER and Microphone Power Supply AC Operated
 List Complete **\$225**

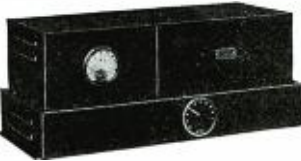

Highly efficient. Portability simplifies installations. Level indicator; attenuator calibrated in decibels. 3 stages amplification bring mike level to maximum + 10 DB for phone line input. 20" x 9" x 11". Weight 40 lbs.

Send for particulars. Attractive trade discounts.

REMLER COMPANY, Ltd.
 19th and Bryant St. San Francisco

FREE
 13th ANNIVERSARY RADIO CATALOGUE

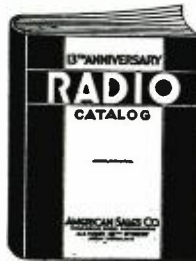

124 pages containing thousands of the greatest radio and electrical values at real bargain prices.

Send for your copy now!
American Sales Company
 Wholesale Radio Distributors
 RE-44 West 18th Street
 New York City

PIEZO ELECTRIC CRYSTALS
 "Superior by Comparison"

Why You Should Use Scientific Radio Service Crystals

- 1 Since 1925, we have been specializing in producing Piezo Electric Crystals exclusively.
- 2 Since 1925, Scientific Radio Service Crystals have stood the test and are recognized the world over for their Dependability, Output and Accuracy of Frequency.
- 3 Since 1925, owners of Broadcast and Commercial Short Wave stations have found that no chances can be taken in getting the cheaper grade of crystals and that invariably they call on Scientific Radio Service for the Best.
- 4 Since 1925, we could be depended upon to make Prompt Shipments. This coupled with a crystal Second to None considering Output and Accuracy of Frequency has earned during these years a reputation which we jealously guard. Therefore, Get the Best.

Price list sent upon request

SCIENTIFIC RADIO SERVICE
 "The Crystal Specialists"
 124 Jackson Avenue, University Park, Hyattsville, Maryland

WAXES, COMPOUNDS and VARNISHES
 for insulation of condensers

- transformers, coils, power packs, pot heads, sockets, wiring devices, wet and dry batteries, etc. . . . WAX SATURATORS for braided wire and tape. WAXES for radio parts . . . Compounds made to your own specifications if you prefer.

ZOPHAR MILLS, INC.
 FOUNDED 1846
 Court and Lorraine Streets Brooklyn, N. Y.
 Agents: Ralph E. Clark, 2907 Calumet Ave., Toledo, Ohio
 H. A. B. Sneve Co., San Francisco, Seattle, New Orleans

HOTEL LENOX
 NEW LOWER RATES

—but the same dependable service, comfortable rooms and excellent meals that have made this hotel famous among seasoned travelers everywhere.

Convenient location: 3 minutes from Peace Bridge to Canada, 20 miles from Niagara Falls.

Rates: Single, \$2 to \$3.50; Double, \$3 to \$6, Family suites \$6 up.

For booklet and free official AAA road map write
 CLARENCE A. MINER, President, 140 North St. near Delaware

BUFFALO, N. Y.

The New
SHURE AUTOMATIC MICROPHONE FLOOR STAND



At Last! A real Floor Stand that is Silent and Automatic! No Thumb Screws! No Wing-Nuts! No Rattling! Lots of Tension Prevents Sudden Dropping! Raise, Lower, or Turn in any direction without adjustments. Special Mechanism (patent pending). Guaranteed Indefinitely.

Write for Details!!

SHURE BROTHERS COMPANY
 Manufacturers—Engineers
 337 WEST MADISON ST. CHICAGO, ILLINOIS

Will buy radio or audio frequency signal generators. State full particulars.

EDWARD R. JAHNS
 541 EMPIRE BLVD., BROOKLYN, NEW YORK

Waxes and Meltable Insulating and Weather-proofing Compounds

IMPREGNATION—Condensers, Coils, Rubber-Covered and Weather-Proofed Wire, Telephone, and Electrical Cables, Etc.
 SEALING COMPOUNDS—Coils, Condensers, Batteries (Wet and Dry), Pot Heads, Cables, Wiring Devices and Specials.
 FINISHING—All grades of Weather-Proof and Rubber-Covered Wire.
 SPECIAL COMPOUNDS made up on specifications.

CANDY & COMPANY, INC.
 35th STREET and MAPLEWOOD AVENUE CHICAGO, ILL.



CATHODE RAY TUBES for ALL STANDARD UNITS

No longer is it necessary to pay high prices for cathode ray tubes. Du Mont tubes are now interchangeable with other tubes and are available in all standard sizes. Adapters are available permitting the use of Du Mont tubes in any standard cathode ray power unit. These tubes are rugged, thoroughly engineered, and low-priced. They excel in uniformity, long life and brilliancy. Reliable commercial performance can be expected.

A complete line of associated equipment consisting of power supply, sweep circuit, adapters, tube holders, etc., are now available. Technical data on cathode ray tubes and equipment is available upon request.

ALLEN B. DUMONT LABORATORIES
Upper Montclair, N. J.

TYPE 34
PRICE \$25.00

BRASS—BRONZE—COPPER NICKEL SILVER—ZINC PHOSPHOR BRONZE

In Gauges .001 and Thicker. 1/16" to 16" Wide

HOT TIN COATED METALS IN COILS AND STRIPS

THE BALTIMORE BRASS CO.
1206 WICOMICO ST., BALTIMORE, MD.

UNIVERSAL—2 Button-Precision LAPEL MICROPHONE



Get full Broadcast quality reproduction with this precision-built, 2-button lapel microphone—Only 3/8 in. thick—Polished Bakelite Housing—Typical Universal ruggedness.

List Price \$25.00

UNIVERSAL MICROPHONE CO., Ltd.
424 WARREN LANE, INGLEWOOD, CALIFORNIA, U. S. A.



RELIABILITY SIEMENS & HALSKE HIGH VOLTAGE CONDENSERS

USED WHERE
QUALITY COUNTS

MORRILL & MORRILL
30 CHURCH STREET NEW YORK CITY

Sole U.S.A. Distributors of the
Siemens & Halske
Condensers and Resistors

LAMINATIONS

for Audio & Power Transformers
SPECIALIZED METHODS—YEARS OF EXPERIENCE
Wide Variety of Stock Standard Sizes
Dimension and Price Sheets on request
We Also Make
PERMANENT MAGNETS—DIES—TOOLS—
METAL STAMPINGS
Facilities for prompt service

Thomas & Skinner 1100 to 1120
Steel Products Co. E. Twenty-Third St.
INDIANAPOLIS, IND.

For Your Experimental Department

A tube of 500 assorted lugs and terminals — hot tinned for easy soldering.
Price \$1.00



We are also prepared to handle production stampings.
Write Us for Quotations

F. R. ZIERICK MFG. COMPANY
70 E. 131st ST., NEW YORK CITY

... for Tubes • Resistors • Relays ...

Carbonized Nickel
Selvage Mesh
(Patented)
Filament Wire
Grid Wire



RESISTANCE
WIRE
Nickel Chrome
Copper Nickel
Nickel Wire
and Ribbon

GILBY WIRE
MEANS
MAXIMUM PRODUCTION
With MINIMUM SHRINKAGE
GILBY WIRE COMPANY
150 Riverside Ave., Newark, N. J.

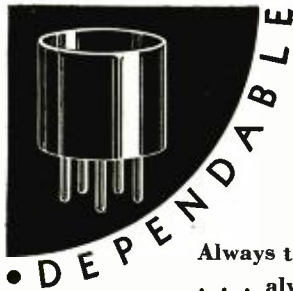

Always the same uniform material . . . always the same uniform moldings . . . rugged . . . attractive . . . economically produced . . . RESINOX is dependable.

**R E S I N O X
C O R P O R A T I O N**

A subsidiary of Commercial Solvents Corporation and Corn Products Refining Co.

230 PARK AVE. NEW YORK CITY

SPECIFY

R E S I N O X

MOLDING RESINS MOLDING COMPOUNDS
LAMINATING VARNISHES

A C M E W I R E

P R O D U C T S

All Acme Products are made to recognized commercial standards, including those of National Electric Mfrs. Assn., Radio Mfrs. Assn. and American Soc. for Testing Materials.

COILS

MAGNET WIRE WOUND

AERIAL WIRE

STRANDED AND SOLID

MAGNET WIRE

ALL INSULATIONS

PARVOLT CONDENSERS

FILTER AND BY-PASS—ALSO FOR POWER FACTOR CORRECTION

VARNISHED INSULATIONS

CAMBRIC, SILK, PAPER, TAPE

THE ACME WIRE CO., NEW HAVEN, CONN.

For over 25 years, suppliers to the largest radio and electrical manufacturers

INDEX OF ADVERTISERS

A	G	S
Acme Wire Co., The..... 30	General Radio Co..... 31	Samson Electric, Inc..... 23
American Transformer Co..... 27	Gilby Wire Co..... 29	Scientific Radio Service..... 28
	Graybar Electric Co..... 1	Shakeproof Lock Washer Co..... 6
B	I	Shure Brothers Co. 28
Baltimore Brass Co., The..... 29	International Resistance Co..... 25	Stackpole Carbon Co..... 27
C	L	T
Candy & Co..... 28	Littelfuse Laboratories 28	Thomas & Skinner Steel Products Co. 29
Central Radio Labs..... 32		Thordarson Elec. Mfg. Co..... 32
Clarostat Mfg. Co..... Third Cover	M	U
Condenser Corp. of America..... 25	Morrill & Morrill 20	Universal Microphone Co., Ltd..... 29
D	P	W
DuMont Labs., Allen B..... 29	Parker-Kalon Corp. 3	Western Electric 1
E	R	Z
Erie Resistor Corp..... Second Cover	Remler Co., Ltd..... 28	Zierlick Mfg. Co., F. R..... 29
	Resinox Corporation 30	Zophar Mills, Inc..... 28

Over 50,000 Calls

LISTED IN EVERY ISSUE



ALWAYS UP-TO-DATE

Including New Call Letters—Changes in Address—Cancellations — "Who's Who" on Short Wave—International Calls and many other features.

If You Are Interested in Short Wave Transmitting or Receiving, You Cannot Afford To Be Without This Book

Radio Amateur Call Book contains Up-to-the-minute Changes in listing new calls, changes in address, and cancellations for over 30,000 licensed Amateurs in the United States and possessions, and over 10,000 licensed Amateur Stations in more than one hundred different foreign countries.

Each issue also contains High Frequency Commercial Stations, Who's Who on Short Wave, Special Stations and Expeditions, International Call Letters, New Prefixes, High Frequency Press and Weather, and Time Signal Schedules.

Truly the Greatest List of Calls Published Under One Cover

SINGLE COPY **\$1.00** ANNUAL SUBSCRIPTION **\$3.25**

Issued Quarterly—March, June, September and December

ORDER YOUR COPY TODAY

RADIO AMATEUR CALL BOOK, Inc.
608 S. Dearborn St. Chicago, Ill., U.S.A.



TYPE 586 POWER-LEVEL INDICATORS

High accuracy and high sensitivity are the features of this power-level indicator. In addition to audio-frequency monitoring they can be used for gain or loss determinations and for equalization measurements on voice circuits.

PRICES (Cabinet Mounting)

—10 to +36 db \$60.00

—20 to +36 db \$75.00

Relay rack models are also available.

Complete information will be furnished on request.

GENERAL RADIO COMPANY
CAMBRIDGE, MASSACHUSETTS

**ON MY WAY TO
NEW YORK AND
THE PICCADILLY**

... best hotel I know!
Near everything, just
200 feet from Broad-
way. Modern, hospita-
ble, and comfortable.
Like the Manager,
like the rates — \$2.50
single, \$3.50 double,
for a room with bath!

**THE HOTEL -
PICCADILLY**
45th St. • W. of Broadway • New York
WILLIAM MADLUNG, Mng. Dir.

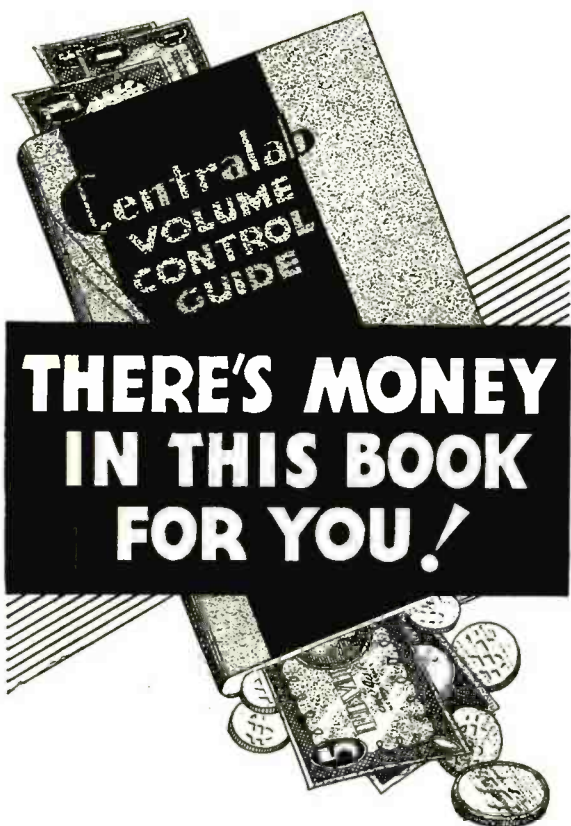

**THERE'S MONEY
IN THIS BOOK
FOR YOU!**

Servicemen and dealers are finding it might profitable . . . this new CENTRALAB VOLUME CONTROL GUIDE.

Replacement business is good business these days . . . are you getting your share? This 50c Guide will be sent to you upon receipt of two three cent stamps to cover mailing costs.

Send for it on your letter head . . . use it . . . discover how a mere handful of Centralab controls will service almost any old or new set.

CENTRAL RADIO LABORATORIES
MILWAUKEE, WIS.

Centralab
CR

THORDARSON DESIGNS NEW TRANSFORMERS

**Keeps in Step with
Requirements of
New Tubes**

SPECIAL TO RECEIVER
MANUFACTURERS:

Makers of radio tubes are making a very significant contribution to the industry with the new type power tubes. These tubes permit maximum amplification with practically no distortion in reproduction.

New Transformers Necessary

This development in the tube field calls for change in transformer design—both in the coupling and the power transformers, in order to accomplish the desired results and achieve the ultimate aims of the tube engineers.

Thordarson Engineers Meet the Demand

Thordarson engineers have developed transformer designs especially to meet the conditions which these new tubes impose, so Power and Coupling Transformers are now available for all new type tubes. Thordarson engineers are in a position to collaborate with manufacturers of radio receivers on their engineering problems. Specifications for your new receivers will be given prompt attention. . . . Thordarson Electric Manufacturing Company, 500 West Huron Street, Chicago, Illinois.

THORDARSON
Reg. U. S. Pat. Off.
TRANSFORMER
SPECIALISTS
SINCE 1895 . . .

CLAROSTAT
TRADE MARK REG. U. S. PAT. OFF.

Replacement Line Ballasts Are Solving Many Problems!



To obtain maximum efficiency and low cost of operation with modern radio sets, the voltage of the power source should be kept to within 5% of the voltage rating for which the set is designed.

A rated 110-115 volt line oftentimes will vary from as low as 90 volts to as high as 140 volts in different sections and at different times during the day, due to differences in distance from the power house, varying loads and poor regulation due to overloaded branch circuits.

Clarostat Line Ballasts will maintain the normal voltage across the primary of the power transformers of sets within the allowable limits for efficient operation in spite of line voltage fluctuations over a range of from 95 to 135 volts. They may be easily installed at reasonable cost.

The main feature of Clarostat Products is their positive reliability. Resistance elements are wound with the highest grade of resistance wire obtainable, on carefully selected and tested Bakelite strips. Tapers are obtained by the time-tried and tested method of proper spacing, shape of winding form and the use of wires of the proper resistance characteristics. Exhaustive accelerated life tests prove conclusively that our units stand up for years under hard service without appreciable wear or change in characteristics. Thus, they cost less than cheap units that are not dependable.



"PS8" Control Without Switch

Free Engineering Service

Clarostat engineers have made special, intensive studies of the needs of various circuits which require the use of wire wound or graphite element volume and tone controls, and the design of units of special resistance and taper characteristics to best suit such requirements.

Let Us Know Your Control Problems!



"MH" Circular Hum-Dinger

CLAROSTAT MFG. CO. INC.

285 NORTH 6th STREET

BROOKLYN, N. Y.



"Midgets" rely on Bakelite Molded

... for attractive, durable cases



MIDGETS are the big "little things" in radio today. Midgets are selling everywhere, and we venture to say that the attractive Bakelite Molded cases in which they

are housed is no small factor in winning acceptance. It takes but two Bakelite Molded parts to complete a case. The instrument housing with ornamental

front is formed in one molding operation, and the paneled back in another. The parts come from the mold with a rich lustrous finish, and require no staining, varnishing, or polishing. The instrument assembly slips into the case without difficulty, and is easily secured in place.

Bakelite Molded is an ideal material for housings, panels, knobs and similar exterior parts of radio receivers. It does not shrink nor swell and is unaffected by heat, cold, or moisture. It retains a high lustre indefinitely and the colors are lasting. To radio manufacturers and engineers we offer the cooperation of our engineers and laboratories in the solution of technical and non-technical radio design and production problems. We also would be glad to mail a copy of our interesting descriptive Booklet 12M, "Bakelite Molded" promptly upon receipt of your request.

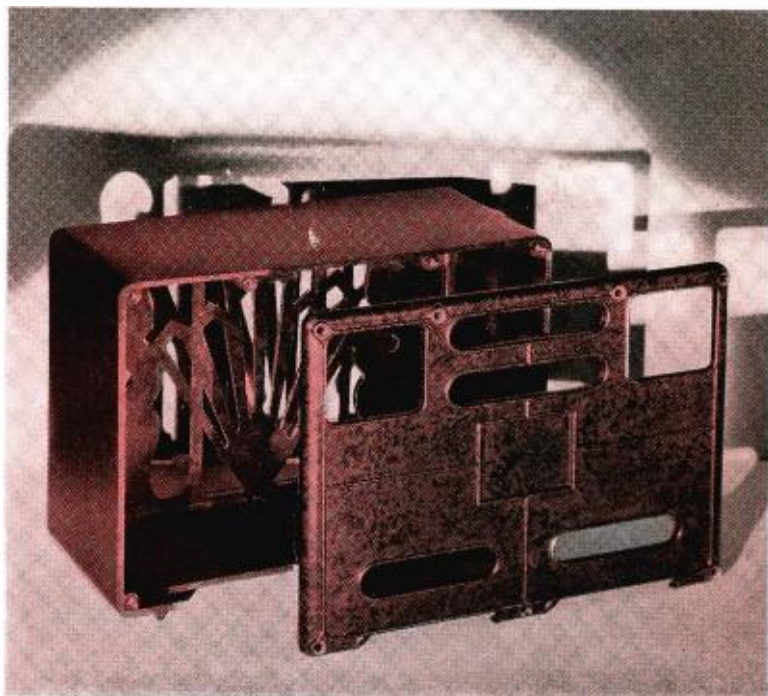

(Above) Emerson Universal Compact Radio complete and (left) view showing construction of Bakelite Molded Case.

BAKELITE CORPORATION, 247 Park Avenue, New York, N.Y. 43 East Ohio Street, Chicago, Ill.
BAKELITE CORPORATION OF CANADA, LIMITED, 163 Dufferin Street, Toronto, Ontario, Canada

BAKELITE

The registered trade marks shown above designate materials manufactured by Bakelite Corporation. Under the Capital "B" is the numerical sign for safety, or unlimited quantity, it symbolizes the safety member of present and future uses of Bakelite Corporation's products.

THE MATERIAL OF A THOUSAND USES